

NATIONAL HISTORIC PARKS AND SITES BRANCH

MANUSCRIPT REPORT NUMBER **127**

1967 EXCAVATION OF THE
PRINCE FREDERICK BASTION 2E20 AT FORT BEAUSEJOUR

by
Winnie Frohn
(1968)

1967 EXCAVATION IN THE PRINCE FREDERICK BASTION
AND MEN'S BARRACKS AT FORT BEAUSEJOUR

by
E. Frank Korvemaker
(1972)

PARKS CANADA

DEPARTMENT OF INDIAN AND NORTHERN AFFAIRS

The 1967 Excavation of the Prince Frederick Bastion 2E20
at Fort Beausejour
by Winnie Frohn

The 1967 Excavation in the Prince Frederick Bastion
and Men's Barracks at Fort Beausejour
by E. Frank Korvemaker

The Manuscript Report Series is printed in a limited number of copies and is intended for internal use by the Department of Indian Affairs and Northern Development. Copies of each issue are distributed to various public repositories in Canada, for use by interested individuals.

Many of these reports will be published in Canadian Historic Sites: Occasional Papers in Archaeology and History, and may be altered during the publishing process by editing or by further research.

The 1967 Excavation of the Prince Frederick Bastion 2E20
at Fort Beausejour
by Winnie Frohn

TABLE OF CONTENTS

Preface.....	ix
List of Illustrations.....	vii
List of Tables.....	viii
Chapter 1. Introduction.....	1
Method of Excavation.....	1
Chapter 2. Stratigraphy.....	4
Surface.....	4
Topsoil: Layer 1.....	4
Layer 2.....	4
(2a).....	5
(2b).....	5
(2c).....	6
(2d).....	6
Stratigraphy in 2E20L area.....	6
Layer 3.....	6
Layer 4.....	7
Layer 5.....	7
Layer 6.....	8
(6a).....	8
(6b).....	8
Layer 7.....	8
Layer 8.....	8
Stratigraphy in 2E20P area.....	9
Layer 1, 2.....	9
Layer 6, (6a).....	9
(6b).....	9
(6c).....	9
Layer 7.....	9
Layer 9.....	10
Stratigraphy in the area over and in the North	
Arm 2E20M.....	10
Layer 3.....	10
Layer 4.....	10
Layer 10, (10a).....	10
(10b).....	11
Layer 11.....	11
Layer 12.....	11
Stratigraphy in the Area of the South Arm of	
2E20M and the South part of 2E20J.....	11
Layer 2.....	11
Layer 3.....	12
Layer 13.....	12
Layer 14.....	12
Layer 15.....	12
Layer 10c.....	12
Layer 12.....	13
Layer 16.....	13

Stratigraphy in North part of 2E20J Area.....	14
Layer 2.....	14
Layer 10d.....	14
10c.....	14
Soil Stain at Juncture of 2E20M and 2E20J.....	14
Stratigraphic Pit in the South Arm of 2E20M.....	15
Stratigraphy on the Exterior of Structures.....	15
Between the well, casemate and south arm of 2E20M.....	15
Layer 1.....	15
Layer 2.....	15
Layer 17.....	15
John Rick's Notes Concerning (a).....	16
Layer 1.....	16
Layer 2.....	16
Layer 13, 14, 15.....	16
Layer 17.....	16
2E20X.....	16
North of the Casemate, Well, 2E20L.....	17
Layer 2.....	17
Layer 18(a).....	17
(b).....	17
(c).....	17
(d).....	17
(e).....	17
To the south of 2E20L and to the west and south of 2E20M.....	18
Layer 19(a).....	18
(b).....	18
(c).....	18
Layer 20.....	18
South of south arm of 2E20M and 2E20J.....	18
Layer 2.....	18
Layer 10(b).....	19
Partially Excavated Stratigraphy of Well.....	19
Layer 2 and 3.....	19
Stratigraphic Interpretation.....	19
Layer 1.....	19
Layer 2.....	20
(a).....	20
(b), (c).....	20
(d).....	21

normal soil.....	21
(a) in 2E20L area.....	21
(b) in 2E20P area.....	21
(c) in 2E20M, n. arm.....	21
(d) in s. arm 2E20M, s. part of 2E20J area.....	22
(e) to north of 2E20J.....	23
(f) north of 2E20K and L.....	24
(g) s. of s. arm of 2E20M and 2E20J...	24
Layer 3.....	24
(a) 2E20L and 2E20M Area.....	24
(b) Layer 2 and 3: 2E20K.....	25
Layer 4.....	25
Layer 5(a).....	25
(b).....	26
Layer 6(a).....	26
(b).....	26
(c).....	26
Layer 7.....	27
Layer 8.....	27
Layer 9.....	27
Layer 10(a).....	27
(b).....	27
(c).....	28
Layer 11.....	28
Layer 12.....	28
Layer 13.....	28
Layer 14.....	28
Layer 15.....	29
Layer 16.....	29
Layer 17.....	29
Layer 18(a).....	29
(b).....	29
(c).....	29
(d).....	29
Layer 19(a).....	30
(b).....	30
(c).....	30
Layer 20(a).....	30
(b).....	30
Soil Stain at Juncture 2E20M-J.....	30
Stratigraphic Pit.....	30
General Notes on Stratigraphy.....	31
Chapter 3. Structures.....	32
Casemate: 2E20J.....	32
South Arm of Passageway 2E20M.....	36
North Arm of 2E20M.....	41
Rock Piles 1 and 2.....	45
Palisade.....	46
Other Wood Remains: Wooden Beam to north of 2E20G and F.....	46
John Rick's Notes.....	47

Chapter 4. Summary and Conclusions.....	47
References.....	54
Appendix: 2E16.....	86

LIST OF ILLUSTRATIONS

Fig. 1:	Location of the surface sub-operations and 2E20 cross-sections	56
Fig. 2:	Key plan of 2E20	57
Fig. 3:	Prince Frederick Bastion contours	58
Fig. 4:	Horizontal stratigraphy of the topsoil	59
Fig. 5:	Soils below topsoil	60
Fig. 6:	Location of mortar detritus areas	61
Fig. 7:	Features of stratigraphy located in 2E20	62
Fig. 8:	Reconstruction of possible door (2E20M8)	63
Fig. 9:	Plan of 2E20J roof	64
Fig. 10:	Plan of 2E20 excavation	65
Fig. 11:	Stratigraphy of Layers 13 and 14 above south arm of 2E20M	66
Fig. 12:	Photograph of the bottom of the mortar detritus layer at the entrance of 2E20M from 2E20L	67
Fig. 13:	Photograph of the soil stain at the junction of 2E20M and 2E20J	68
Fig. 14:	Photograph of 2E20J, showing remains of wooden roof	69
Fig. 15:	Photograph of the drain, west wall of 2E20M and the west wall	70
Fig. 16:	Photograph of the possible door (2E20M)	71
Fig. 17:	Photograph of the north end of the west wall of 2E20M	72
Fig. 18:	Photograph of the palisade remains	73
Fig. 19:	Photograph of the north part of the casemate 2E20J	74
Fig. 20:	Photograph of the remains of the wooden roof on the south wall of 2E20M	75
Fig. 21:	Photograph of the 2E20J casemate, especially the "third face" of the curve	76

LIST OF TABLES

Table 1: Lot-layer Correlation	77
Table 2: Roofs of 2E20J and 2E20M	80
Table 3: Walls of 2E20J and 2E20M	81
Table 4: Corners of 2E20J and 2E20M	84
Table 5: Dimensions of Bricks in 2E20	85

PREFACE

The 1967 excavation of the Prince Frederick Bastion took place from May 15, 1967 to September 3, 1967, during the excavation season at Fort Beauséjour, which lasted from May 15, 1967 to September 15, 1967. The Archaeological Director was Jervis Swannack; the Assistant Director was DiAnn Herst.

The excavation of the Prince Frederick Bastion was carried on by myself and my assistant, Frank Korvenmaker (23), and the following workmen: (The number of workmen varied throughout the season; those mentioned below were the ones present for the greater part of the season.)

Dean Scapie--foreman

Jim Cousins

Willis Goodwin

Leo Hachey

Ron Murphy

David Rogerson

Seymour Sears

Roland Wells

The amount of earth excavated was approximately 1007 dump cars and 321 wheelbarrows. Assuming that a dump car contains about 1.5 cu. yds. of earth and that one dump car contains about nine wheelbarrows, the amount of earth excavated was approximately 1564 cu. yds.

The notes of John Rick and Ian Rodgers on the 1962 test trenches (2E5A and 2E5B) dug in the interior of the bastion were also used.

CHAPTER I: INTRODUCTION

The purpose of this report is to describe the method and finds of the 1967 excavation of the Prince Frederick Bastion, and to reconstruct, whenever possible, the structures and history of the Prince Frederick Bastion. In order to accomplish this, the report will deal with the methodology of the excavation, the stratigraphy, the architecture of the casemate (2E20J) and the passageway branching off the passageway leading to the well, that is 2E20M branching off 2E20L. There will also be a discussion on the drain found in 2E20M, the two rock piles, one near the casemate, and the other at the S/W corner in 2E20M; and the palisade. (Figs. 2 and 10) Other features, such as the well and the passageway to the well, are discussed in the report of Frank Korvemaker (67-23).

This report will also attempt to incorporate the notes of John Rick and Ian Rodger on the 1962 test trenches dug in the interior of the Prince Frederick Bastion. Their notes dealing with test trenches at the base of the escarp and in the left face of the escarp will not be discussed.

The method of excavation was as follows (Fig. I): a trench, 2E20G, was dug in the area approximating the position where the passageway (leading to the well) 2E20L, started from the parade ground, according to map HM 15414 (Nadon: 1966). Subsequently two more trenches were laid out: 2E20F was to continue excavation of the passageway to the well and also to uncover part of the well; 2E20E was to excavate part of the branching passageway (2E20M) and part of the well (2E20K). 2E20C and 2E20D were laid out to excavate the remainder of the well and part of the casemate; 2E20A and 2E20B were dug to uncover the rest of the casemate. Another trench, 2E20N, was dug in order to uncover completely the south wall of 2E20L, and 2E20P was dug in order to

uncover the drain found in 2E20L. In most cases, the original dimensions of the suboperations were changed in order to completely uncover the features found. Three foot wide balks (2E20H) were left between most of the suboperations in order to preserve stratigraphy and allow passage of the wheelbarrows. These balks were originally intended to go through the middle of the features as determined from historical sources, but due to the unexpected orientation of the casemate, this did not turn out to be the case. Once architectural features were recognized the interiors became separate suboperations (Figs. 2 and 10). The well became 2E20K; the passageway leading to the well became 2E20L, and the drain found below the level of 2E20L became 2E20P. All these features are discussed in the report of Frank Korvemaker (67-23). The casemate became 2E20J; the branching passageway, 2E20M.

The test pit, 2E5A, of the 1962 excavation of John Rick could be distinguished on the surface and through the stratigraphy (which will be discussed in the next chapter); it was, therefore, excavated as 2E20X. The other test trench, 2E5B, could not be distinguished, and was therefore not dug as a separate suboperation (Fig. 1).

As far as possible the digging followed the stratigraphy. The interior of the architectural features were dug to the floor or, where there was no floor, to the lowest point of the structure, except for the well which has not been completely excavated. In other words, 2E20J and the part of 2E20M which had a cobble stone floor base was dug down to this level, while the rest of 2E20M was dug down to the bottom of the walls, partially exposing a drain found in this passageway and not part of the drain referred to as 2E20P. 2E20L was dug down to the bottom of the walls and

down to the cobble stone floor except in the drain (2E20P) which was dug down to its floor.

The earth exterior to the features was not removed down to the same depth. The well was excavated down from 1.5' to 3.0' on the outside. The casemate exterior was dug down approximately 1', i.e. one to three courses on the outside. 2E20M was dug down one course of stones (approximately 0.7') on the outside, except at the juncture with 2E20L where the west wall was dug down 3'. 2E20L's exterior was dug down one to two courses of stones, approximately 1.0'.

In general the excavation of the Prince Frederick bastion started from the west and moved east. Balks were left to preserve stratigraphy at strategic points, and the interiors of the features were treated as separate suboperations. The interiors of the features were excavated as completely as possible, while the exteriors were examined only for the top several courses of masonry in most cases.

CHAPTER 2: STRATIGRAPHY

Surface

The surface (Fig. 3, Table 1) of Prince Frederick Bastion was covered with the usual grass and weeds found at the fort. On top of the ramparts the grass was more sparse than on the interior or exterior of the bastion. The turf and most of the topsoil was missing in the area where a modern cement base had been removed just prior to excavation. Turf also seemed to be missing in a haphazard way from the left flank in a 1' wide strip to a 10' x 10' area where the grass was much sparser and coarser than the surrounding turf. On both flanks, the earth profile seemed to descend into the interior of the bastion in two steps, from the parapet to a lower level, and from this lower level to the inside of the bastion.

Layer 1: Topsoil

The topsoil (Fig. 4, Table 1) had an average thickness of .5'. In the highest parts of the bastion it consisted of a dark brown loam (7.5 YR; 4/4). The lowest part of the bastion, and the part most steeply inclined, was dark brown loam (7.5 YR; 3/2), and the earth between these two extremes was dark, reddish-brown loam (5 YR; 3/4).

Layer 2

The layer below the topsoil was, in general, dark reddish brown sandy loam (5 YR; 3/4), becoming more clay-like with increasing depth (Fig. 5, Table 1). Inclusions consisted of decayed wood, black in colour, often field stones of varying sizes, and sometimes bricks, whole or broken, sometimes patches of mortar detritus, and sometimes patches of reddish-brown sandy loam (5 YR; 4/4) or dark

brown silty loam (2.5 YR; 4/4), which was probably decomposed wood. Cases where the soil below Layer 1 was not dark, reddish-brown sandy loam (5 YR; 3/4) were the following four types:

- (2a) Cross-sections 67-37-D3a,b and -D6, - D11 show, in the west part, the stratigraphy south of 2E20L. Soils 5 and 6 take the place of the normal soil of Layer 2, but only for the top part of the layer. Soils 5 and 6 abutted the south wall of 2E20L at the top. Below the top of this wall, the exterior soil is the same soil as the normal soil of Layer 2. Soils 5 and 6 continue farther south than the 3.5' excavated south of the south wall of 2E20L (2E20N9, 10,11). Between Soil 6 and Soil 4 (the normal soil of Layer 2), there was sometimes Soil 3, dark brown sandy loam (7.5 YR; 3/2) containing decomposed matter and many artifacts, such as square nails, pottery, glass, bone and a button. This soil was excavated as 2E20G11. Soil 3 spilled into 2E20L, widening out to 10' from 6' and sloping downwards toward the middle of 2E20L.
- (2b) To the north of 2E20L, the normal soil of Layer 2 was again not directly under the topsoil (67-37-D22a,b; -D23a,b; - D13). Between, was usually a layer of dark brown, sandy loam (7.5 YR; 4/4)--Soil 1b-- which became dark brown, sandy loam (7.5 YR; 3/2) nearer to 2E20L (67-37-D7, - D21). In other words, the situation to the north and south of 2E20L is the same. Approximately 8' to 10' from 2E16 the arrangement of various soils entitled Soils 10 appears. This area continues down below the limit of excavation (approximate elevation at the bottom is 127' ASL) so that the area is at least 3.5' deep and approximately 1.2' wide at the top and 1.7' at the bottom limit of excavation. From the west wall of 2E20C to 3.5' west of this point, soil 1b is missing, and replaced by the normal soil of Layer 2.

- (2c) The five easternmost feet of cross-sections 67-37-D3a,b; -D6, and -D11 show the topsoil, darkbrown loam (7.5 YR; 4/4)--Soil 14-- which is then followed by an old turf line, and in turn, followed by Soil 7, a dark reddish-brown loam (5 YR; 3/4); Soil 4 follows this.
- (2d) Above the area of the well, the Soil 4 replaces, for a while, the normal soil of Layer 2 (67-37-D5).

Stratigraphy in the 2E20L area

Layer 3

In 2E20L, below Layer 2, was found a layer of soil with a high concentration of mortar detritus (Figs. 6, 11; and 67-37-D3a and b, -D6, - D11). This layer partly covered the area above the walls of 2E20L, though usually it did not go down to touch the walls, where, at this point, it usually was .01' thick gradually increasing until it had a thickness of approximately 1.5' in the middle of 2E20L. The concentration of mortar detritus became less dense and in a much thinner layer 7' from the west end of the south wall of 2E20L to the west end of the same wall. There were two kinds of mortar detritus: (3a) a heavily concentrated layer was found particularly in the area joining 2E20M and 2E20L. On the 2E20M side the mortar detritus ended very abruptly, just leaving a thin band approximately .05' wide (Fig. 7; 67-37-D10a,b). The mortar detritus layer seemed to slope from 2E20M into 2E20L. (3b) a less concentrated layer of mortar detritus, similar to that found at the west end, was found under the heavy concentration. In this layer the artifacts were not very frequent; however, there were many brick fragments, shell, and decomposed wood.

Layer 4 in the 2E20L area

Below Layer 3, there was a layer of dark reddish-brown loam (5YR; 3/4) approximately 1.5' thick in the middle of 2E20L to .01' thick on the walls of 2E20L. Layer 4, like Layer 3, covered partially the area of the walls of 2E20L, sometimes reaching down to actually touch the walls. The concentration of the inclusions: shell, decomposed wood, charcoal pieces, mortar detritus, and many artifacts, was heaviest in the same area where the mortar detritus in Layer 3 was concentrated. The artifacts included two buckles, musket balls, buttons, pins, bottle fragments, part of a metal crest, a pair of scissors, and parts of cutlery.

Layer 5 in the 2E20L area

Below Layer 4 were two soils (5a) dark, reddish-brown sandy clay (5 YR; 3/4) with rubble in the area joining 2E20M and the rest of 2E20L to the east, going down to the cobble stones, and in the area of 2E20L to the west of 2E20M; (5b) the soil was dark brown, sandy loam (7.2 YR; 3/2) plus field stones. The approximate thicknesses of the layers were 2' to .6'. These soils covered the walls where Layers 3 and 4 did not already touch the walls. Layer 5 mostly contained rubble, and few artifacts; however, in Layer 5b a pile of 38 cannonballs, with an average diameter of .35', though they were covered with rust, and therefore, these dimensions are not accurate. A 'possible' iron clamp was found, lying on top of Layer 5b, or covered by approximately .2' of this soil. Most of the cannonballs were within 2E20L, though about 6 were on top of the south wall of 2E20L, and one (which was included as an artifact in 2E20G14) was found approximately .5' to the south of the south wall of 2E20L. All the cannonballs were found 12' to 18' from the west end of the south wall of 2E20L, at an average elevation of 127' ASL; all

(except for the one included in 2E20G14), and the clamp was considered as lot 2E20G18.

Layer 6 in the 2E20L area

(6a) At the approximate elevation of 126.9' ASL from approximately 10' east of the west end of the south wall of 2E20L, and westward, extending into 2E20P and under the bricks of 2E16 to the wall of 2E16, dark brown loam (7.5 YR; 3/2) an arganic trash layer, with coal pieces, coal ash and charcoal pieces, was found. At the west end of 2E20L the soil did not cover the entire surface of 2E20L, and was rather thin, when it did: approximately .01' from the west end of the south wall of 2E20L to 2' west from the west end of the south wall of 2E20L. Elsewhere the thickness of the soil varied from .4' to .05' (Fig. 7). The east end of this soil is that of the area around the field stones discovered in 2E20L, and which were considered a possible collapsed archway (Korvenmaker 1967).

(6b) In the area which was not covered by the above mentioned soil, the soil was dark brown loam (7.5 YR; 3/2) approximately .3' thick, and the artifacts were very few.

Layer 7 in the 2E20L area

Below Layer 6, the soil became reddish brown, sandy clay (5YR; 3/4) from 3' to .7' thick. The artifacts were exceedingly sparse. The top of this layer usually coincided with the bottom of the walls of 2E20L. Below the walls, the soil consisted of reddish-brown, sandy clay (5YR; 4/3) also, usually full of small rocks, which had an average size of approximately .15'.

Layer 8 in the 2E20L area

From 10' east of the west end of the south wall of 2E20L, the soil

to the east remained Layer 5a; to the west Layer 5b was followed by dark, reddish-brown, sandy loam (5 YR; 3/4) at the approximate elevation of 126.5' ASL.

Stratigraphy in 2E20P--the drain area

Layers 1 and 2 in the 2E20P area

In the extension to the west of 2E20L excavated to follow the drain beyond the 2E20L area (2E20P1 through 2E20P6), the turf was only partially present since the drain went under the 2E16 area of excavation (2E16C). Where the topsoil, Layer 1, had not been removed, it was dark brown loam (7.5 YR; 3/2) approximately .5' thick. In this layer, in 2E16, on the exposed surface, and in Layer 2a, rocks were found with an average size of 1.5' x .7' x .6'. The artifacts in the above mentioned areas were the usual sherds and square nails. Under Layer 2a, Layer 2 was found in a thin layer, containing a great deal of brick pieces.

Layer 6a in the 2E20P area

In the extension mentioned above, Layer 6a immediately followed Layer 2.

Layer 6b in the 2E20P area

In the above-mentioned area, Layer 6b followed Layer 6a.

Layer 6c in the 2E20P area

In the extension mentioned above, Layer 6c, consisting of dark brown, loamy sand (7.5 YR; 4/4), approximately .5' thick, followed Layer 6b.

Layer 7 in the 2E20P area

Layer 7 followed Layer 6c down to the bottom of the excavation, outside the drain (approximately 124.5' ASL). Sometimes patches of

Layer 9 were found in Layer 7.

Layer 9 in the 2E20F area

The soil inside the whole drain varied from dark brown sandy clay (7.5 YR; 4/2) to dark brown sandy clay (7.5 YR; 3/2).

Stratigraphy in 2E20M--North Arm area

Layer 2 of the north arm area of 2E20M

The soil of Layer 2 goes down to approximately 1' above the walls of the north arm of 2E20M, except in the curved part of the west wall where it goes below the walls to 127.5' ASL. The approximate elevation elsewhere is 129' ASL.

Layer 3 of the north arm area of 2E20M

Near the well and the opening to 2E20M, Layer 3 was found (mortar detritus concentration). It narrowed immediately to approximately .05' thick, and as such, went 6' to the south near the well, and just touched the west wall of 2E20M where it joins 2E20L (67-37-D8, -D10a, b, and Fig. 6). The mortar detritus layer near the well was at the approximate elevation of 132.7' ASL--that is, at the top of the well; while the approximate elevation at the west wall of 2E20M was 133.6' ASL.

Layer 4 in the north arm area of 2E20M

The thickness of this later varied from .05' to 1', but usually it was approximately .1'. It lay directly under Layer 3.

Layer 10 in the north arm area of 2E20M

(10a) At approximately 1' above the walls (129' ASL), except in the area of the curved wall, at the juncture with 2E20L, where the point

was at 127' ASL, the soil on top of the walls was dark brown clay (7.5 YR; 4/2) with a mixture of reddish-brown clay (5 YR; 5/3) and greyish-brown clay (10 YR; 5/2--marsh mud) with decomposed wood.

(10b) At the same elevation as Layer 10a, above the interior of the north arm of 2E20M, the soils became a mixture of dark reddish-brown, sandy clay (5 YR; 3/4)--the same soil as Layer 2-- and dark brown sandy clay (7.5 YR; 3/2 or 7.5 YR; 4/3), also with decomposed wood. This layer was from 1.5' to 2.4' thick (67-37-D8, -D26)

Layer 11 in the north arm area of 2E20M

At the approximate elevation of 125' ASL, the soil became reddish-brown, sandy clay (5 YR; 4/3) at the north end. In the southern part, more and more dark reddish-gray, sandy clay (5 YR; 4/2) was mixed in; and 2' below the top of the layer, the whole north arm was a mixture of the two soils, and the large wooden planks or split logs (discussed later) had been uncovered. The mixture continued down to the drain, except for the area of Layer 12. The artifacts were extremely scarce.

Layer 12 in the north arm area of 2E20M

In the southernmost 5' of the north arm of 2E20M, the soil became dark brown sand (7.5 YR; 4/4) at the approximate elevation of 122.8' ASL (Fig. 7).

Stratigraphy over the South Arm of 2E20M and the Southern Part of 2E20J

Layer 2 over the south arm of 2E20M and 2E20J, south part

Layer 2 was approximately 1.5' thick (67-37-D17a, b; -D6; -D14; - D12; -D5; - D18).

Layer 3 over the south arm of 2E20M and the south part of 2E20J

Mixed in with Layer 2, were patches of Layer 3 at about the level of the well and higher, approximately 131.7' ASL. These patches were only found in the vicinity of the well, and directly south of it. There seemed to be no definite pattern to the patches except that the elevation at which they were found increased approximately by one foot in the southernmost patch, i.e., the one furthest from the well (67-37-D17a,b). Artifacts were sparse.

Layer 13 over the south arm of 2E20M and the south part of 2E20J

This layer was directly below Layers 2 and 3. It consisted of a mixture of dark brown, sandy loam (7.5 YR; 4/4 or 7.5 YR; 4/2) and strong brown, sandy loam (7.5 YR; 5/6). This mixture was found directly above the middle of the structures, where the roof would probably have collapsed. The mixture formed a "v" shape (Fig. 11). On both sides of this "v", the soil became Layer 14.

Layer 14 over the south arm of 2E20M and the south part of 2E20J

This soil is the same as Layer 2. It surrounds Layer 13.

Layer 15 over the south arm of 2E20M and the south part of 2E20J

This layer surrounds Layer 14 and consists of a mixture of the soils of Layers 13 and 14. This layer goes down to the top of the walls, or one course deeper, at the approximate elevation of 125.5' to 126.5' ASL.

Layer 10c over the south arm of 2E20M and the south part of 2E20J

This layer, as the other Layer 10's of 2E20M, is on top of the walls. The soils are reddish-brown sandy clay (5 YR; 4/3) often with patches of dark brown sandy loam (7.5 YR; 3/2). This layer continued down along the walls of the interior, but the soils here were more clearly defined: the reddish-brown sandy clay (5YR; 4/3 is closest to the

walls approximately .2' wide, then a dark soil, usually dark brown sandy loam (7.5 YR; 3/2) .2' follows; then another layer of sandy clay (5 YR; 4/3), then another layer of the dark soil. Sometimes the layers would broaden out even to 1' wide. This alternation of soils was often found right down to the floor base, though it usually stopped at Layer 12 (67-37-D27).

Layer 12 over the south arm of 2E20M and the south part of 2E20J

This layer is the same as that of Layer 12 of the rest of 2E20M. It was found on the cobblestone floor base and also in the extreme western part of the south arm of 2E20M, where there was no cobblestone floor base (Fig. 7).

Layer 16 over the south arm of 2E20M and the south part of 2E20J

The layer above Layer 12, in the interior of the structures, consisted of dark reddish-gray, sandy clay (5 YR; 4/2), and nearer the walls, reddish-brown sandy clay (5 YR; 4/3) was also found.

Artifacts found above the southern part of 2E20J and the south arm of 2E20M were sparse; however, in the strong brown, sandy loam above the casemate, an iron rimmed wooden wheel was found at the approximate elevation of 131' ASL. It was in lot 2E20H26; the diameter of the wheel was 1.5'. Also found were bottle fragments, felt or leather soles, faience sherds, a French gunflint, and some bone. In the western end of the south arm of 2E20M, a large iron concentration was found, and some hinges, which will be discussed later.

Stratigraphy in the North Part of 2E20JLayer 2 over the north part of 2E20J

The thickness of this layer was 3.5' (67-37-D12; -D5; -D18).

The soil remained the same colour but became more clay-like down to one foot above the casemate (approximately 130' ASL). The total thickness of this layer varied from 5' to 7'.

Layer 10d over the north part of 2E20J

This layer, as the other Layer 10's, is on top of the walls, below Layer 2. The layer consists of decomposed wood, preserved wooden chips, clays and 'marsh mud': reddish-brown (5 YR; 4/3); dark yellowish-brown, sandy clay (10 YR; 4/4); and dark gray clay (5 YR; 4/1). These soils spilt down into the interior for approximately .5' to an elevation of 127.5' to 126.5' ASL.

Layer 10c over the north part of 2E20J

The interior of the north part of 2E20J had the same layers as the south part of 2E20J (67-37-D27). Artifacts above the casemate were very scarce. Inside the north part of 2E20J the artifacts included square nails, leather or felt soles, a French gunflint, and bottle fragments (67-37-301).

Soil Stain at the Juncture of 2E20M and 2E20J

Where the west wall of 2E20J joins the north wall of 2E20M, an area was found consisting of strong brown clay (7.5 YR; 5/6) and a concentration of nails (Fig. 6, 13). The soil stain first appeared at the elevation of 128.75' ASL in the west part and at 128.2' ASL in the east part. The layer was very thin, approximately .05', then there was a layer of partially decomposed wood, approximately .02' thick, and then a layer of yellowish-red clay (5 YR; 5/8) with numerous nails (Fig. 13). Below this layer (approximately .05' thick)

was the normal soil of the interior of the casemate.

Stratigraphic Pit in the South Arm of 2E20M

In the westernmost area of the south arm of 2E20M, a pit measuring 2.5' N-S x 1.5' E-W was excavated to an elevation of 121.3' ASL in order to investigate the stratigraphy below Layer 12. The soil at that elevation was reddish-brown sandy clay (5 YR; 4/3). The sand had gradually become more and more mixed with the clay (Fig. 7).

Stratigraphy on the Exterior of the Structures

Between the well, casemate, and the south arm of 2E20M-exterior

(67-37-D14; 67-23-D6)

Layer 1- exterior

This was the normal topsoil.

Layer 2 - exterior

The normal soil gradually became more clay-like with depth. This layer was approximately 6' with an inclusion of brown loam (7.5 YR; 4/2) stretching to the east of the well down 4.5' with the top of the inclusion being approximately level with the top of the well. Approximately .5' from the bottom of our excavation (127.8' ASL) the soil changes to Layer 17.

Layer 17-exterior

The soil is reddish-brown clay (5 YR; 4/3) and started at the approximate elevation of 128.3' ASL and went below the limit of the excavation (127.8' ASL). The artifacts were very scarce. The above information concerns only the area not excavated by Rick (Fig. 1).

John Rick's Notes Concerning the above Layers 1,2,17 (62-1-164,171,174)Layer 1

The cross-sections have a topsoil of soft reddish-brown sandy clay, except for the "northern face" (--according to Rick's notes; according to our arbitrary location of North, it is the "western face"), where the topsoil is soft brown sandy clay.

Layer 2

Below Layer 1 is a layer, very stony, with Layers 1 and 2 intermixed (this was the case in the 1967 excavations when we were dealing with earth outside the structures). The normal Layer 2, as previously described, was sometimes called "pink" by Rick.

Layers 13, 14, 15

These layers are described above in the areas of 2E20M and 2E20J.

Layer 13 slants down into the south arm of 2E20M, or into the well;

Layer 14 follows below, as does Layer 15.

Layer 17

At the top of the north wall of 2E20M, and partly down the well (at the approximate elevation of 127.8' ASL), the soil becomes "pink clay" with a lens of soft yellowish-brown sandy clay. This soil right at the bottom of Rick's excavation becomes mixed with a small amount of brown, sandy clay and bluish-gray clay. The only artifact mentioned is a "wooden door" at the elevation of approximately 122.4' ASL, right at the bottom of the excavation, and the bottom of the north wall exterior of 2E20M (62-1-141,151). The door was approximately 2.5' x 2', and seemed to have been burned or broken off.

2E20X- a partial re-excavation of Rick's excavation area

The excavation was not complete, since we only went down to the first course of the north wall of 2E20M, approximately 127.5' ASL. Soil was

a mixture of Layers 1, 2, and 17.

Stratigraphy to the North of the casemate (2E20J), well (2E20K) and 2E20L

Layer 2 - to the north of 2E20J, 2E20K, 2E20L

This layer was approximately 3' thick. From the well east, the soil colour remained the same below the 3', but the soil became sandy clay with many rocks, which will be discussed as RockPile 1 in structures.

Layer 18 to the north of 2E20J, 2E20K, 2E20L

(18a) To the west of the well and rockpile mentioned above, a small lens of very dark, grayish-brown loam (10YR; 3/2) and old turf was found on top of Layer 18b.

(18b) This soil lay also to the west of the rock pile. It was dark brown loam (7.5 YR; 2/3) and field stones.

(67-37-22 a,b; - D23 a,b; and -D13). This layer sloped down toward the west and went below the limit of excavation at about 2' east of the point facing perpendicularly the west wall of 2E20M joining the south wall of 2E20L.

(18c) For about the western most 3.5' of Layer 18b, Layer 18c covered it, and also an additional 4.5' to the west.

(18d) To the west of soils 10 on 67-37-D22 a and b, there was a layer of brown loam (7.5 YR; 5/4) approximately 0.8' thick.

(18e) Below 18d the soil became strong brown loam (7.5 YR; 5/6) and brown, loamy sand (7.5 YR; 5/2). This layer went below the limit of excavation.

The artifacts found to the north of 2E20L were very scarce, and consisted of the usual square nails, pot sherds and bone. The artifacts to the north of 2E20K and 2E20J were also scarce.

Stratigraphy to the south of 2E20L and to the west and south of 2E20MLayer 19 to the north of 2E20J, 2E20K, 2E20L

- (a) Below the normal Layer 2, dark reddish brown sandy clay (5 YR; 3/4) and dark brown sandy clay (2.5 YR; 3/2) stretches from the juncture of 2E20M and 2E20L westward 4.5', sloping downwards.
- (19b) The soil along the west wall of 2E20M approximately 2' south of 2E20L becomes dark reddish brown sandy clay (5 YR; 3/4) with many small stones (approximately 0.2' x 0.2' x 0.1') and with a width along the wall of approximately 0.75'. This band of earth continued along the entire west wall of 2E20M.
- (19c) Elsewhere to the west of the west wall of 2E20M the soil was dark brown loam (10 YR; 4/4) and reddish brown clay (5 YR; 4/3) and field stones. In this earth wood pieces and wood molds were found (Fig. 7).

Layer 20 (to the south of 2E20L)

Below Layer 19a two other soils were found, one beside the other; dark reddish brown sandy clay (5 YR; 3/4) to the east and dark brown, sandy clay (7.5 YR; 4/4) to the west and stretching out for approximately 7' and then descending beyond the limit of excavation (approximately 126.' ASL).

Stratigraphy south of the south arm of 2E20M and 2E20J

The stratigraphy is not too clear because usually the limit of excavation did not extend this far south; however, in the most eastern part of the area to the south of 2E20M and 2E20J we were able to ascertain the stratigraphy beyond the structures.

Layer 2 (south of south arm of 2E20M and 2E20J)

Below the usual layer of topsoil (7.5 YR; 4/4) there was a Layer 2b

which usually made the difference between the parapet and the rest of the bastion; the average thickness was 2.5'. Below this layer, the usual Layer 2, was found mixed with Layer 2b (in this soil the palisade remains were found).

Layer 10b south of the south arm of 2E20M and 2E20J

At 3' from the bottom of excavation to the lowest point, the soil became Layer 10b. Artifacts to the south of 2E20M and 2E20J were scarce, but did include a large knife blade approximately 1.6' long at the approximate elevation of 131.5' ASL.

Partially Excavated Stratigraphy of the well (2E20K)

Layer 2 and 3

The usual soil of Layer 2 was found down to and within the well, often with patches of Layer 3, especially near the walls.

Stratigraphic Interpretation

Layer 1

The three different soil colours may be due to different drainage, depending on the incline and the soils underneath (e.g. whether there is mortar detritus or clay underneath).

The soils may also have been deposited at different times. The dark brown loam (7.5YR; 4/4) is similar in colour to Layer 2b and was probably used with this layer to build up the parapets (this will be discussed under Layer 2b). The dark reddish-brown loam (5 YR; 3/4) is similar to the normal soil of Layer 2 and was, therefore, probably deposited at the same time as this layer. The dark brown loam (7.5 YR; 3/2) may have been deposited to fill out the bottom of the bastion of the parade ground.

Layer 2

First the cases where Layer 2 was not immediately dark reddish-brown sandy loam (5 YR; 3/4) will be discussed: The area where the topsoil was followed by another layer of the same colour but usually with more sand and stones seems to be found at the high points of the bastion (Fig.5); that is, the parapets. We know from Nadon's report (1966) that the salient angle was raised in 1755, and traverses placed on each flank. This would reasonably explain the double layers, but Layer 2 would already have to be deposited.

Layer 2a

Soils 5 and 6 seem to be fill of the bastion deposited after Layer 2, and therefore could be part of the raising of the parapets. Soil 3 seems to be a lens in these soils, and would seem to be a trash layer.

Layers 2b and 2c

Soil 1b seems to be the result of raising the parapets. The Soils 10 on cross section 67-37-D22a,b could represent the side walls of the merlon--a merlon at Fort Beauséjour apparently constructed like a wood box with earth filled inside (Swannack: personal communication). It could be part of a postern seen on a map of 1779 (Nadon 1966), though the area of Soils 10 seems too small; however, maybe the area to both sides where the Soil 1b is missing for a distance of 9' E-W should also be considered. The area more to the east missing Soil 1b is probably the location of John Rick's 1962 test trench, 2E5B, which could not be detected accurately on the surface. The regular stratigraphy has been cut through down to 1.5' at least, and the old turf (9a and b on 67-37-D23 a and b; -D13) has been covered up. The trench was supposed to join 2E5A (partially re-excavated as 2E20X) with a trench running up the side of the rampart. According to John Rick when he visited the

site in 1967, the trench was supposed to be approximately 1' wide and 1.5' deep. These dimensions seem to fit the stratigraphy. The soil removed while digging the trench, and later refilling, would explain why the turf in the five most eastern feet of 67-37-D3 a and b; -D6; -D11 was covered by Soil 14.

Layer 2d

The pit-like area must have been recently filled since it was deposited when the topsoil was as at present. It may have been necessitated by the gradual settling of the soil in the well, the deepest structure in the bastion.

Layer 2: normal soil

There seems to be two separate uses for this soil: as part of the bastion to make the ramparts above the previous gun platforms (which will be discussed later), and to fill in after collapse, as in 2E20L and at least the top part of 2E20M (above Layer 3).

(a) In 2E20L area

Here Layer 2 is used as fill of passageway. It was probably deposited at the same time as Layer 3, since Layer 3 would have blown away if it had been left exposed to the wind, as it is mainly mortar detritus.

(b) In 2E20P area

Here Layer 2 seems also to be fill.

(c) in the 2E20M, North arm area

Since Layers 3 and 4 cover the deeper part of Layer 2, Layer 2 must have been partly deposited before Layers 3 and 4. It may have been deposited after the north arm of 2E20M was filled in,

since the bottom of Layer 2 is fairly level; or the Layer 2 up to Layer 3 may have originally been part of the earth covering above the roof of 2E20M. Certainly the soil above Layer 3 could not have been part of the original roof covering since the mortar detritus layer (Layer 3) slopes down to fill up 2E20L. If Soil 5 on 67-37-D8 was originally part of the earth above the north arm of 2E20M, and assuming that at the time of the collapse, the fill of 2E20M did not come directly from above, but also from the exterior of 2E20M, and considering that the interior is approximately 5.5' deep, we can imagine that the original surface level could be 8' above the top of 2E20M, or approximately 135.5' ASL (the present height of the bastion). The difficulty with this suggestion is that there is no trace of previous sod, nor of a collapse pattern in the stratigraphy. The well would also have been filled up. The other possibility that Soils 2-5 (i.e. Layers 1-4) and even perhaps Soil 6 (Layer 10b) are the fill after collapse would make the top elevation of the earth above the north arm approximately 129.5' ASL and the layer above the walls 1-3' except at the curve where it would perhaps slope down to the actual wall (130.2' ASL). There is still the problem that no sod remains, but we now do have collapse stratigraphy and the well is not filled in.

(d) in the south arm of 2E20M and South part of 2E20J area

Layer 2

Here Layer 2 has also been used as fill for the bastion. Again it shows no sign of being used to fill a collapse but is over Layers 13--15 which either fill in the depression caused by a collapse, or are partly the soil over the roof

of 2E20M and the south part of 2E20J (67-37-D17 a and b; Fig. 11).

This part of Layer 2 was presumably deposited at the same time as the Layer 2 of 2E20L, and the top part, at any rate, of layer 2 in the 2E20M area.

(e) Layer 2 in the area of the north part of 2E20J and surrounding area

In the north part of 2E20J, the walls and the roof did not collapse a great deal. The roof only sank approximately 1' below the top of the walls. The stratigraphy is then mostly undisturbed (67-37-D12, 67-23-D5, 67-37-D18). The top layer of Layer 2 (where the soil is still sandy loam) seems to be ordinary fill of the bastion. The lower part of Layer 2 (Soil 4) seems to be the covering of the roof of 2E20J and to form a parapet to the north. The elevation of the layer (3' thick), above the casemate is approximately 130' ASL, which seems to fit with the elevation of the original covering for the north arm of 2E20M, and is also the approximate elevation for the top of the roof covering layer 10c in the south arm of 2E20M and the south part of 2E20J.

If the present surface level were the roof covering level before the structures fell into disuse, the elevations would be disproportionate with the other elevations calculated above.

Unfortunately we do not find traces of sod. If the bottom level of Layer 2 were the ground surface during the utilization of the structures, the parapet, judging from 67-37-D12; 67-23-D5; 67-37-D18, would have a top elevation of approximately 134' ASL. The well would not be covered over either.

(f) Layer 2 to the north of 2E20K and 2E20L

To the north, Layer 2 seems to be fill of the bastion, and was presumably deposited at the same time as Layer 2 in the area of 2E20L, when the passageway had fallen into disuse.

(g) Layer 2 to the south of the south arm of 2E20M and 2E20J

The highest elevation of the palisade holes was 129.8' ASL. This would also be the top of the bastion and roof covering of 2E20M and 2E20J. The soil above this would probably be deposited at the same time as the Layer 2 top part above 2E20J, and Layer 2 above the south part of 2E20J and the south arm of 2E20M.

Layer 3

(a) 2E20L and 2E20M

This layer is probably a trash layer since shells and brick fragments were found in it. The pieces of mortar were many shapes as though they had once covered a flat surface with occasional angles. The only possible reason for the mortar detritus seems to be that it is garbage fill of the depression caused when 2E20L and 2E20M fell into disuse. There is no evidence for mortar being used in the walls except for the upper part of the well. Since the mortar detritus layer covers the areas of 2E20L walls, it must have been deposited when 2E20L and, therefore, 2E20M had fallen into disuse. For reasons mentioned above, Layers 3 and 2 were deposited at the same time. The mortar detritus and soil may have come from another area since we can find no source for it from 2E20.

(b) Layers 2 and 3 in 2E20K

The mortar detritus here may be due to leaching of the walls.

If we are correct in our assumptions that during the utilization of the structures, the well was not covered with soil, the soil in the well may have been deposited later than the collapse of the structures. Since the soil is similar to Layers 2 and 3, probably the well was filled at the same time as Layers 2 and 3 were deposited. But this is only true for the depth we have excavated. The well may have been filled in, partly, much sooner.

Layer 4: 2E20L and 2E20M

This layer is in the same area as Layer 3 in 2E20L and the north arm of 2E20M, and must, therefore, have been deposited after 2E20L and 2E20M fell into disuse. The layer seems to be a trash layer used as a fill of the depression left by the passageways.

Layer 5 (2E20L)

(a) this soil is found on top of 2E20L walls and also in the interior.

The layer must have been deposited after the disuse of 2E20L.

Since the walls of 2E20L are not intact, the earth may have settled down into the passageway from behind the walls of 2E20L, or, more likely, the layer outside and inside 2E20L was deposited at the same time. The soil is the same as Layer 2, and probably Soil 5 was deposited at the same time as the bottom level of Layer 2 in the north arm of 2E20M, and at the same time, perhaps, as Layers 2,3 and 4. Part of the soil may also have been the original ground level of 2E20L, after the drain was not used (this will be discussed later), and if the grill uncovered in 2E20L was part of the drain system, (for surely the grill would just be in the way and should be covered up, either by soil, or

by a wooden floor.)

- (b) This soil also covers the interior of 2E20L and its walls; it must, therefore, have been deposited after disuse of 2E20L.

The soil seems to be fill, and possibly also topsoil, indicating an original ground surface. This would explain why the soil is loam, as opposed to (a) which has more earth on top of the layer, since it is farther into the gorge of the bastion. Cannonballs are part of the fill.

Layer 6 (in 2E20L and 2E20P)

- (a) This soil has not been analyzed, but the workmen were generally agreed that it was coal ash, and the colour is suitable to coal ash (Encyclopaedia Britannica 1910:576). David Rogerson, one of the workmen, said that many of the farmhouses still used coal ash for waterproofing foundations since the coal ash becomes impermeable when wet. However, for this use, if coal ash can be compared to cinders, at least 12" to 18" is required (Gay 1932:113). Since the coal ash layer found was only from 0.05' to 0.4', and since it was unevenly spread and did not cover the whole passageway or area above the drain, the purpose of waterproofing must be rejected. Considering the great number of artifacts, Layer 6a is probably a trash layer.
- (b) Probably this soil is really a continuation of Layer 5b.
- (c) This soil may be the equivalent of Soil 11 on 67-37-D22 a and b, since the elevations and colours resemble each other. Its purpose seems obscure, perhaps a former occupation level, after the drain was not used, and before the trash layers 6a and b were deposited; or the soil may just be fill of the bastion.

Layer 7 (2E20L)

This soil goes under the walls of 2E20L and covers the drain. This indicates that the drain was no longer used when 2E20L was built. Probably the drain was used in conjunction with the well, which fell into disuse at least by 1754 (Nadon 1966). The drain could have been covered at some time after, or even before this date. The well, itself, appears on a map of 1751 and 1752 (Nadon 1966). So the drain was built some time between 1751--1754.

This soil resembles that found in the stratigraphic pit below the floor level and wall level of the south arm of 2E20M.

Layer 8 (2E20L)

This soil resembles Layer 2 and Soil 5a and is probably the soil below the topsoil Layer 5b. All of these above Layers were probably deposited at the same time.

Layer 9 (2E20P)

This soil was probably deposited when the drain was abandoned and it may be topsoil from the colour, and because this soil would probably be most likely to be available. Outside the drain: Layer 7.

Layer 10 (2E20M and 2E20J)

- (a) This soil is the original roof covering of 2E20M's north arm; the darker colours of the soil are due to decomposed wood and "marsh mud."
- (b) This is also the roof covering of the north arm of 2E20M, which has partly filled the collapsed interiors, also fill of bastion.

(c) This soil is the roof covering on the south arm of 2E20M, and 2E20J. The alternating layers of lighter and darker soils are caused by wood stain from the two layers of the roof. Since the roof collapsed, the layers continue down along the walls.

Layer 11

In the interior of the north arm of 2E20M, the soils were not for the top 2', a mixture of reddish brown sandy clay (5 YR; 4/3) and dark reddish gray sandy clay (5 YR; 4/2). At the northern end the soil for the top 2' was only reddish brown sandy clay (5 YR; 4/3) which could possibly be considered as part of Layer 2, indicating that the soil covering above the roof of the north arm of 2E20M was extremely thin.

Layer 12(north and south arms of 2E20M and in 2E20J)

The sand was probably used for drainage of the floor base of the south arm of 2E20M and 2E20J, the sand is also found partly in the north arm of 2E20M in order to lead the water completely away and to the drain of the north arm of 2E20M.

Layer 13 (south arm of 2E20M and south part of 2E20J, and the area of Rick's excavation)

This soil, as well as Layers 14 and 15 are part of the fill of the structures after their collapse, and also in the area between the structures and the well where the earth slid down to fill in 2E20M, or had been empty before.

Layer 14 (in south arm of 2E20M and south part of 2E20J and in the area of Rick's excavation)

This soil serves the same purpose of Layer 13.

Layer 15 (in south arm of 2E20M and south part of 2E20J and in the area of Rick's excavation)

This soil serves the same purpose as Layers 13, 14.

Layer 16 (in south arm of 2E20M and 2E20J)

This layer was the original roof covering of the south arm of 2E20M and 2E20J (Layer 11 resembles this layer very much). It now fills the collapsed interiors.

Layer 17 (in area of Rick's excavation) p. 15, 16

This layer resembles Layer 7 and the stratigraphic pit below the floor level of the south arm of 2E20M. Perhaps this is the subsoil natural to the fort, or the base for the entire bastion.

Layer 18 of 2E20J, 2E20K, 2E20L

- (a) If our assumptions are correct, this soil and turf are the old occupation level when the structures of the bastion were in use. The elevation of the bastion would be 131' A.S.L. at this point which fits in with our other elevations.
- (b) this soil could be the remains of the gun platforms (Nadon 1966) which were built before the construction of the casemate, and/or the bastion after the construction of the casemate.
- (c) this soil resembles very much Layer 2, except it is more clay-like, and it could have been deposited at the same time as Layer 2.
- (d) and (e) These soils could be the remains of the gun platform or the original occupation levels before construction of the bastion. If 18e were ground level, its top elevation would be 125.7' ASL.

Layer 19 south of 2E20L, and south and west of 2E20M

- (a) This soil seems to be the habitation level after the construction of 2E20M.
- (b) This soil seems to be a footer trench, along the west wall of 2E20M.
- (c) This is probably the original gun platform, the yellowish colour of the soil may be due to wood stains. The palisades constructed before the gun platforms (Nadon 1966) are also surrounded with this soil.

Layer 20 south of 2E20L

- (a) The dark reddish brown sandy clay (5 YR; 3/4) could be the backdirt pile created when the footer trench to the west wall of 2E20M was dug.
- (b) The dark brown, sandy clay (7.5 YR; 4/4) was perhaps the original habitation level (elevation at top, approximately 127' ASL).

Soil Stain at Juncture of 2E20M and 2E20J

This soil stain was probably caused by the iron nails. The concentration of iron nails was probably necessitated by the pattern of the planks on the roof of 2E20J and 2E20M; many planks would have come together at this point.

Stratigraphic pit

This pit probably revealed the subsoil or the base for the bastion. Similar soil was found under 2E20L (Layer 7) and under the north wall of 2E20M in Rick's excavation.

Perhaps mention should be made to the cross-section in Rick's notes on 62-1-180; the stratigraphy shown is supposed to be from 2E3B, not 2E5B; however, Rick said that there was a cross-section for 2E5B, and this seems to be the nearest to what would be expected. In any case, the stratigraphy agrees with what we found in the other cross-sections.

General Notes on Stratigraphy

The different phases of the stratigraphy are: the original ground surface before the French started work; the surface of the gun platforms; the surface of the bastion and French construction; possible destruction by British, leaving no clear stratigraphic indications; possible reconstruction by British; fill in of collapsed or disused area; Layer 2 may be part of the last mentioned or have been deposited later with layers 3 and 4; raising of the level of the bastion and the development of the topsoil probably occurred at the same time.

It does not seem possible to establish any absolute dating.

CHAPTER 3 STRUCTURES

For discussion and description, the areas for which I am responsible for structurally are: the casemate (2E20J), the south arm of the passageway 2E20M, the north arm of the passageway 2E20M, the door sill (?) and other door (?) remains found in the S-W corner of 2E20M, the drain which was uncovered in 2E20M, and miscellaneous items including the two rock piles and palisade and other wood remains. The features will be discussed in order above.

Casemate Roof - 2E20J:

Remains of the roof were best preserved on top of the walls, in those areas where the walls themselves were best preserved, i.e., the north wall of the casemate, the northern part of the western and eastern walls and the curve which took the place of the SE corner of the casemate (Tables 2, 3, 4). The roof was composed of two layers of wood, either split logs, with the flat side pointing up, or hewn logs, or small whole logs. A thin layer of earth was found between the two layers of wood, and also often under the first layer of wood a thin layer of rust, stain approximately 0.01' thick was found, and less often, also on top of the first layer

In the north part of the casemate the lengths of the wood were laid parallel to the north wall in both layers (Fig. 9). In the southern part of the casemate the top layer of wood has the lengths of wood also running parallel to the north wall of the casemate; the layer below has the lengths of wood running parallel to an imaginary line joining the NW corner with the middle of the curve (Fig. 14). The wooden roof in the north part, from the north wall to an imaginary line projected east from the north side of the north wall of 2E20M, (approximately 4.5' from the south face of the north wall of 2E20J)

was found at a higher level (at approximately 126.95' ASL at the highest point) than the southern part where the highest point was approximately 126.' ASL, except for along the walls and rubble where wood was found from the top down. Between the north and south sections a split log was found joining the second layer of the northern part of the roof with the bottom layer of the southern part of the roof, i.e., running from the east wall at 124.8'AS.L. to the west wall at 123.75' ASL.

The roof in the north part was found approximately 0.75' to 0.8' below the east wall of 2E20J (126.8' ASL) at the bottom of the second course of stones. The roof continued from the east wall level for approximately 3.5' then sloped abruptly downwards towards the west so that the roof was found from 3.2' to 3.4' below the top of the west wall (approx. 125.5' ASL), at the bottom of the sixth or seventh course of stone. The wooden roof's top layer did not touch the walls, but an approximately 0.07' wide band of earth lay between the walls and the roof.

As well as being found lower, the roof of the southern part of 2E20J was not as well preserved, being more fragmentary. Nails were found in the wood, but not in sufficient number to show any arrangement. On top of the curve the nails seemed to have been placed in line with each other, often with as much as a foot between them (67-37-23I,2).

The second layer of wood was usually located directly under the first layer of wood, though in the case of the southern part, the orientation was different as mentioned above.

The roof did not reach out to cover the walls entirely. A border of

stone, from 0.7' to 1' wide was left exposed. This may be because the wood rotted away at these areas though there seems to be no reason why the wood would rot here and not elsewhere.

Walls of 2E20J: These were made of field stone and sometimes "pierres cassées". As far down as one course on the outside the walls were composed of an exterior and interior face with a rubble core. In the curve another face had been abutted. Only the north wall, approximately 3' from the south face of the north wall to the south along both east and west walls, and the curve were intact. Stones were lacking especially in the east wall from 4.5' from the interior face of the north wall to the curve, and in the corner which joins 2E20M and 2E20J. Coursing was both regular and irregular. No mortar was found in conjunction with the walls.

For measurements of the wall, refer to Table 3. The approximate height of the west wall was 6' (top elevation: 128.85' ASL), that of the north wall: 6' in the west (top elevation: 128.75' ASL) to 4.9' in the east (top elevation: 127.65' ASL). The approximate height of the east wall was 4.8' (top elevation: 127.6' ASL) and that of the curve 4.6' (top elevation: 127.3' ASL). From this it may be seen that the roof would slope from the west down to the east (difference of approximately 1.1') and with a slight slope from north down to south (0.1' difference approximately). This slope was probably intended to drain water away from the casemate.

The plan of the walls made it possible to go deep into the salient angle with the curve.

Floor (2E20J)

The floor (Fig. 10) was composed of a base of chape with dark brown sand (7.5 YR; 4/4) in between the stones (average size: 0.2' x 0.3' x 0.15'). At intervals a depression for sleeper beams was left (from 0.5' to 0.9' wide with an average depth of 0.2'). In the north part the lengths of the depressions were parallel with the north wall, and traces were found of 3 depressions with approximately 3' between. In the southern part, at the corner of 2E20J and 2E20M, one depression ran from the corner south to 2E20M's south wall, and another depression joined the N-S depression at its south end with the west end of the southernmost E-W depression. The elevations on the floor varied from 122.95' to 122.65' ASL. The floor was probably wooden planks resting on the sleeper beams which were placed in the depressions in the chape.

On top of the chape, wood pieces were found approximately 2' x 0.7' x 0.3' - 0.1' (on the average, but sizes varied greatly). The wood seemed to be hewn planks, but the state of the wood was fragmentary. Especially the north part of 2E20J contained this wood, but there seemed to be no definite pattern. The approximate elevation of the wood was 123.2' ASL. If this wood is the remains of the floor, the floor had an average elevation of 123.2' ASL and was composed of planks 0.7' wide and 0.1' thick lying on top of the chape and the sleeper beams in the depressions and attached to these by the numerous square nails found on the floor near the depression or in them.

Artifacts found on top of the possible wooden floor were a French gun flint (67-37-242) and bottle fragments. Artifacts on floor base were nails and a French gun flint (67-37-301).

Interpretation of Features of 2E20J

The Wooden Roof of 2E20J

The southern part of the roof in 2E20J was probably oriented in a different direction for each of the two layers in order to reduce the strain of the weight of the earth above the weak point where 2E20M's south arm turns to become 2E20J (Fig.9). The planks (approximately 0.2' thick and from 0.6' to 1' wide) probably were partly tapered so as to fit the "pie piece" shape of the 2E20M-J curve. Since every plank required nails to hold it down, the nails at the 2E20M-J corner would be much closer together than elsewhere, due to the tapering of the planks, and this would have caused the large soil stain discussed under stratigraphy. Probably some of the planks were nailed to the roof of the south arm of 2E20M.

The extra "face" on the Curve of 2E20J

This curve seems to have been added later than the wall was built, since it is abutted, though this may have been done merely to facilitate construction. Its purpose is clearly to help support the weight of the roof at the weak point.

2E20M: South Arm of Passageway

Roof

The remains of the roof were mostly on the south wall at 1' from the curve of 2E20J west 6' and from 9.6' from the curve 7' west (67-37-239, 252). Other remains were found lying along the north wall especially and also in the interior from an elevation of 126.3' ASL and deeper (67-37-297).

Up to Wall A (Fig.2) a possible door jamb, and only to the east of this wall, the wood lengths on the walls and the interior lay perpendicular

to the walls.

The roof up to Wall A resembles greatly the roof of 2E20J. It was probably composed of planks approximately 0.2' thick and 0.6' to 1' wide lying perpendicular to the walls, with a layer of clay approximately 0.07' thick between. There was a slight slope down towards the west also (difference of approximately 0.3' from the north wall top elevation of approximately 127.85' to the south wall top elevation: approximately 127.5' ASL).

Walls

The walls of the south arm of 2E20M were made of field stones and "pierres cassees", for the south wall as far down as one course on the exterior, at least (the limit of excavation) and for the north wall, all the way according to my notes and John Rick's. The walls have two faces and a rubble core. The north face of the north wall of 2E20M, according to John Rick's notes, has a plinth at the bottom consisting of two courses of stone, the first course sticks out 0.48' more to the north than the stone above, and the plinth stone below stocks out 0.03' more to the north in turn. The height of the plinth seems to be about 1.1' (62-1-141,143). The plinth was not found in the interior.

The purpose of the plinth may just have been as a firm foundation for the north wall of 2E20M. Or perhaps the original plans for the bastion were to use the well as part of the passageway leading to the casemate: the north wall of 2E20M would then have served as the south wall, and the plinth may have been intended for a wooden floor. This is the design on all the plans which show 2E20J (Naion 1966). The French or the English, perhaps in 1812 when a stone casemate is mentioned as being constructed (Nadon: personal communication), changed the

construction to the present, a rather awkward set up.

Wall A

This wall (Fig. 2) juts out from the south wall. It is bonded to the south wall in its top course, and otherwise abutts. It is missing part of its stones. The north face is bonded. It probably served as a door jamb to Sill 3 (Fig. 2).

North and South Walls

The average height of the north wall from the chape floor base to the top of the exterior wall (which was complete at the beginning of the excavation though some later fell down) is 4.9' at the east end (approximate top elevation: 128.85' ASL) and 5.45' at the north arm (127.85' ASL: approximate top elevation).

The average height of the south wall of 2E20M is 4.9' (approximate top elevation: 127.5' ASL) at the east end, by the curve of 2E20JJ and 5.1' at Wall A (top elevation: 127.5' ASL) and 4.41' at the SW corner (Top elevation: 127.5' ASL).

The roof would therefore slope down towards the south from 2E20J to Wall A, and to the west from Wall A west.

A great deal of the north wall, on the interior, was missing (Tables 3, 4), while the south wall was intact at the beginning of the excavation except for Wall A, but part of the south wall did fall during excavation.

Floor: South Arm of 2E20J to the Wall A resembled very much the floor and floor base of 2E20J. In the eastern part, the floor had been preserved (Fig. 10). It consisted of planks running E-W with a thickness of 1.5' and an average width of 1', over sleeper beams approximately 0.7-0.9' wide and approximately 0.2' deep (though the sleeper beams were not possible to examine very closely since the top planks were not removed). Approximate elevation of the floor was 122.95' ASL.

The sleeper beams were also placed in depressions similar in dimensions to those of 2E20J, and running N-S. Originally there would probably have been four depressions in 2E20M running N-S from the north to the south walls, at the approximate interval of 3-4'.

Sill No. 3

The space between the north wall and Wall A is 4.2' approximately, wide enough for a door. If this really is a door sill, it would explain the purpose of Wall A (Door jamb); however, Sill 3 could just be a depression for a sleeper beam for the floor. No inset has been found in the north wall.

Floor to the West of Wall A

In this area of the south wall of 2E20M and north into the north arm of 2E20M for 5' north of the north face of the north wall of 2E20M, dark brown loamy sand (7.5 YR; 4/4) was found, but no stones (Fig. 7). Traces of wood were found. A small plank 1.2' E-W, by 2' N-S lay to the west of Door Sill 3. The floor could have been supported by Door Sills 2 and 3, and consisted of wooden planks, the small area would need no other drainage than the sand and the

drain of the north arm of 2E20M.

The Possible Door (2E20M8)

A beam, on the south face 6.' from the south wall at its western end and 6.7'; at its eastern end 6.7' was found (Figs. 2 and 8). From east to west it measured 3.3'. At its western end the measurement N - S was 0.5' and the same at the east end. Its depth was 0.15 '. The top elevation at the west end was 125.8' ASL; at its east end, 126' ASL. The beam was cased on all sides with iron, from 0.02' - 0.05' thick (Fig. 16). The grain of the wood ran E - W. Along the west and east walls of 2E20M in this area metal traces were found at 6'.6' from the inner face of the south wall. The metal remains were also found inside the inset in the west wall (Fig.8). To the south a great deal of sheet iron was found on the rubble. The average thickness was 0.07'. The largest piece of iron sheet was 0.5' X 0.3' X 0.01'. Two pieces were riveted together with wood facing out on the back of one of the sheets. A great deal of wood pieces were also found in this area. 3 hinges were found, one still had wood around the point, another had the rod inside the hole.

We seem to have evidence of a door as drawn on Fig. 8. The sheet iron encased the door because 2E20J and 2E20M's south arm probably acted as a powder magazine (Nadon 1966), and because the walls are thick and stone; therefore, protection against fire may have been necessary, though the floor would hardly have been wooden if this were the case. Perhaps a solid door was considered as essential protection against the enemy. The door

obviously collapsed or was destroyed.

Sill No. 2

Below the possible door, a depression full of wood stained earth and pieces of wood was found (Figs. 2 and 8). The top of the depression was at 122.7' ASL. The floor level elsewhere and the bottom was at 122.3' ASL.

The south arm of 2E20M has such a wide space and such a similar construction to that of 2E20J that probably it can be considered part of the casemate rather than considering 2E20J, alone, as the casemate.

North Arm of 2E20M

ROOF

The indications of a wooden roof in the north arm of 2E20M (Tables 2,3,4) were: (1) actual wood found along the west wall of 2E20M, almost entirely after the higher curved part of the west wall, consisting of a 12' plank lying on top of the wall from the west part of Rock Pile 2, and at 7' from the north end of 2E20M, another plank, 5' (E-W) X 1' (N-S) lay across the plank along the wall, on top; (2) wood stained soil with nails, on the rubble and east wall of 2E20M. There were also occasional wood pieces which continued down along the rubble; wood remains at the approximate elevation of 125.3' -6' ASL. This consisted of two planks stretching almost to Door Sill No. 2 (though at a higher level). Planks lying at right angles and below the two lengthwise beams were also found.

It is difficult from such meager evidence to imagine the roof.

It seems to have consisted of four or more planks running along the passageway and above these planks running across the passageway. But the evidence is not sufficient.

Walls of the north Arm of 2E20M

The walls consisted of field stones or "pierres cassees" with coursing sometimes regular and sometimes not, in the west wall. In the east wall no courses had been preserved. At least down to one course of most of the north arm on the exterior, and for the curved part at least five courses down, the walls were composed of two faces with a rubble core. The west wall was complete except in the north part of the curve--at the beginning of the excavation. Part of the wall fell during excavation. The east wall's inner face was completely missing, and the top looked as though some stones were also missing.

Behind the east wall stones were filled in to join the well. The east wall, when it reached 2E20L, sloped downwards (probably the wall had partly fallen down and should have been at the elevation of the rest of the wall: 125.8' ASL at least, or higher to match the curve of the west wall to 130.2' ASL (if there were a roof) and then crossed over to 2E20M's west wall, level with the cobble stone floor of 2E20L (124.55' ASL). Here there seemed only to be the one face to the south, and none towards 2E20L (Fig. 15).

West Wall juncture with the south wall of 2E20L

This corner is difficult to interpret because part of both walls were missing (Fig.17). However, the stones were probably bonded as elsewhere.

Inset in the West Wall

At 6' from the SW corner of 2E20M an inset in the west wall was found, 0.7' E-W x 1' N-S, this was probably for the door post for the possible door (2E20M8) discussed above. No inset was found in the east wall, but the condition of this wall was very poor.

The curve of the north arm of 2E20M

The north arm of 2E20M seems to be too narrow for any other use than a passageway except in the curve in the west wall where it joins 2E20I. The curve may have allowed for the swing of the door of Sill No. 1 (Fig.2), though surely they could have made the door swing the other way. It may have contained a sort of sentry box for a soldier to protect the casemate. (Swannack: personal communication). There does not seem to be enough archaeological evidence for a definite explanation.

Drain of the North and South arm of 2E20M

The drain was not completely cleaned while I was at the excavation; therefore, I cannot be as definite in my description as I would like to be. The drain followed the east wall of 2E20M and, according to Swannack, continued adjacent to the north wall of 2E20M to 2E20J. The drain, was covered with large field stones, the average size being 1.7' across the drain, 1.2' along the length of the drain, and 0.55' thick (Fig.15). The drain itself had an average width of 0.8' and an average depth of 1.1'. On the south side and later west side of the drain smaller stones were exposed, approximately 0.07' x 0.15' and these may have served as fill around the drain and as a floor base, though they were only found for the northern

most 4', for sure. The drain goes under the west wall of 2E20L (top elevation of drain: 123.7' ASL). A wire and flashlight was used to investigate under 2E20L. The drain continues under 2E20L west for 5', and then seems to curve into the area of the interior of 2E20L.

Since the drain of 2E20M goes under the south wall of 2E20L for at least five feet, these eastern most five feet of 2E20L's south wall and probable all 2E20L must be of later construction than the drain.

Floor of the north arm of 2E20M

The floor could have been made of wood with the drain serving as a plinth, and the small stones along the drain serving as a floor base. The drainage was not as important here as in the other structures since the north arm is too small for storage. The floor could just have been packed earth.

Door Sill 1

At the entrance to 2E20M a cavity 0.4' N-S x 0.4' deep, and running the length of the entrance (7.3') was found. On the north side of the cavity wood and metal form the wall. Part of the NE corner of the cavity also had remains of wood. Directly to the south of the cavity charcoal pieces and string brown clay (7.5 YR;5/6) was found, and directly below some iron remains. This could be traces of a door. A large number of nails was also found (67-23-222).

Considering that the only explanation of Door Sill 1 seems to be that it once contained a door frame, it seems likely that what was behind the door was covered. True, the east wall of 2E20M is not the same height as the west curve of 2E20M, but the east wall is not complete in its present state. The roof of the north arm of 2E20M would have

to cover less area than the south arm of 2E20M, and therefore, less wood remains have been found.

Rock Piles 1 and 2

The two rock piles could either be left over rocks after construction of the structures, or part of the original gun platforms erected in 1751 or 1952 (Nadon 1966), or they could be part of the ramparts erected in 1752-3.

Rock Pile 1

The largest size of the natural rocks (Fig.7) was 1.6' x 1.1' x 0.7'; the smallest was 0.4 x 0.4' x 0.3': the average size was 1' x 0.8' x 0.5' 67-37-D22 a and b, and 67-37-D13. The stones were placed closely together in either dark, reddish-brown, sandy clay (5YR;3/4) or usually reddish-brown, sandy clay (5 YR; 4/3). The rock pile started at an approximate elevation of 130.6' ASL and went down to 128.3' ASL then, it moved right against the casemate north wall and went down another 1' and then seemed to cover both this area and go under the original rock pile once more. However we did not excavate any deeper on the outside of the casemate. The rockpile continued into 2E20B, following the casemate, but gradually the rock tapered out keeping to its top elevation.

Rock Pile 2

The average size of the stones (Fig.7) was 0.9'x 0.7'x 0.5' (67-37-D8 and 67-37-D17 a and b). The top elevation of the rock pile was approximately 129.5' ASL. and the bottom of the rock pile seemed to be at the level of and resting on the south part of the west wall of 2E20M.

The Palisade

The palisade was found along the south limit of the excavation; that is to the south of the south arm of 2E20M and 2E20J and stretching into the salient angle as far as we excavated. It stretched from the east limit of the excavation 23.6' along the southern limit of excavation. The actual wood appeared from an elevation of 130.80' to 129.54' ASL. (For an impression of what remained of the wood, see Fig.15). Where the wood had not been preserved, the earth was wood stained, and often holes were found before the actual wood was found, or where no wood had been preserved at all. The top elevations of the holes were from 134.5' to 129.8' ASL. The palisade was found at approximately 2.2' north of the surface southern limit, but because of the slope of the excavation walls the palisade could not be excavated to any great extent. The wood was exposed at most in length downwards, and usually only 0.5'. The width of the wood N-S was usually 0.08'; the width of the wood E-W was varying from 0.2' to 0.4'. Sometimes there seemed to be two layers of wood going from south to north. In this case earth, approximately 0.15' thick would be found between the layer. The palisade was found in a mixture of dark reddish-brown sandy loam (5YR;3/4) and dark brown loamy sand (7.5 YR;4/4); for accurate measurements see 67-37-257,273. The wood remains, though not found everywhere, were found very closely placed, touching each other in some places, and this is how a palisade would be constructed.

Other Wood Remains: Wooden Beam to north of 2E20G and 2E20F

The beam, 13' long and 0.4' at its widest end was found at an elevation of 132' ASL. In the west end it was 2' BS, as also in the east

end. Other smaller pieces were associated with it, and some spikes (Fig.4, 67-23-71). A plan of 1755 shows a traverse, as does plan HM 15414 (Nadon 1966). Possibly the beam was part of the traverse.

John Rick's Notes 62-1-180.1

Perhaps I should mention these notes as I mentioned them in the Stratigraphy section. The trench is called 2E3B, while we are concerned with 2E5B, yet, perhaps it is the same trench, since he is noting things from the Prince Frederick Bastion in this part of the notebook, and it seems to be the only trench that vaguely resembles our requirements. At the end of the trench closest to the ramparts we see some stones described as part of the curtain wall.

CHAPTER 4; SUMMARY AND CONCLUSIONS

This chapter is intended to summarize and conclude the previous pages. First, some general statements. The number of artifacts found in the entire bastion was very scarce except in the organic trash layers. This probably means that people had time to clean out any desired materials, such as wood from the floor, stones (I presume) from 2E20L. The fact that so much of the walls of 2E20M and 2E20J was intact, or with rubble near by sufficient to have completed the wall would suggest that stones were not removed since this was impossible or dangerous due to the earth on top of the roofs. This seems to further strengthen the argument that the north arm of 2E20M was covered both by a wooden roof and earth.

We are not sure of the ground level before the original construction

of the Prince Frederick Bastion was begun if we consider that the top or near the top of the western end of the drain of 2E20P would probably be near ground level, we have an elevation of approximately 125' ASL at parade square surface. For want of any better method of finding the ground level this elevation will be used as such.

Analysis of artifacts will be extremely useful in dating. Most of the artifacts seemed to be English except possibly a few faience sherds near the floor of 2E20M and 2E20J, (but not touching).

We will now consider a possible reconstruction of the Prince Frederick Bastion. According to the Historical Report on Fort Beausejour (Nadon 1966), the first period of intensive work at Fort Beausejour was in 1751 to 1752. In a plan of 1751 from this same report, a well and two gun platforms are shown in the Prince Frederick Bastion. Whether these features were already constructed or just intended cannot, of course, be clear. At any rate, the palisade must have been up by this time. From the archaeology we can say the ground elevation may have been 125' ASL. and the highest elevation at which indications of palisades were found was at 134.5' ASL. This would make the palisades 9.5' (approximately) above the ground level. This seems to tally with the Historical Report on Fort Beausejour. By August 1751, Fiedmont says that gun platforms have been completed in the Prince Frederick Bastion as has also an open well. The gun platforms had been supported by packed earth. Do we find any traces of the gun platforms in the stratigraphy? As suggested above, soil 4 on cross section 67-37-D10 a and b; Soil 7, on 67-37-D22 a and b; -D23 a and b,

-D13; as well as soil 10 on 67-37-03 a and b, -06, -D11 may be parts of the original gun platforms, so would also perhaps the soil around the palisades (which is the same as Soil 4 on 67-37-10 a and b).

The soil would then have covered the palisade making a parapet 9.5' above ground level. The elevation would decrease towards the gorge of the bastion, and this is precisely the case on the cross sections which are not close to the palisade and therefore the rampart.

The earthworks covering the palisade mentioned above had probably been begun at least by 1752. On a plan of 1752 we again see the two gun platforms and the well.

The next plan we have is in 1755 where we see a traverse. In the same year we find a drawing indicating Prince Frederick Bastion as the bastion in which a magazine and well are. In the plan GM15414, which is supposed to have been produced soon after the British take-over, we see a traverse, well, casemate, and two passageways, in the approximate locations of where we actually found these features. One of the most glaring differences is the change of orientation of the casemate, yet this would be one of the most difficult features to orient correctly from the inside. From the above we know that the features, except the well of the Prince Frederick Bastion if they were French, were erected before 1755 and after the plan of 1752 was made. Since the casemates are supposed to have been finished by 1753 (Nadon:1966), the features of Prince Frederick Bastion were constructed probably from late 1752 to 1753, or in 1812.

How were the features constructed? Part of the original gun platforms were cut away (as can be seen from the abrupt halt of Soil 4 on 67-37-D10 a and b at the west wall of 2E20M), by 2E20L the gun platforms

had already petered out so that there was no need to cut back. If the palisades had already been covered, probably part of the interior earth was cut away. The walls of 2E20J and 2E20M were constructed; perhaps first an attempt was made to use the well as part of the passage-way leading to the casemate and this was given up or done by the French, and the British changed the structure to present construction.

The casemate consisted of two "wings": 2E20J and 2E20M's south arm up to Wall A. In this area a cobble stone floor with sleeper beams at intervals was made. On top, planks were placed. This was an effort to keep as much moisture away from the interior as possible.

Either before or after the placing of the roof, it was deemed necessary to add the third face to the curve of 2E20J and add Wall A to help support the roof at its weak points. Probably Wall A had been laid before the cobble stone floor since the floor ends at Wall A, but the cobble stone floor could be a later development, though considering the elaborate floors of the other bastions there seems to be no reason why the floor was not laid immediately especially considering the great importance of keeping moisture from the powder. Probably the door frames at Wall A and again at door sill 2 on Fig. 2 also helped support the roof. The roof consisted of two layers of **planks**, split logs with the flat side upwards or logs, depending presumably on the size. In between the layers **marsh mud** and clay was placed. At the curve in 2E20J the layers of wood were oriented in different directions in order to distribute the strain on the wood from the earth above.

The earth above consisted of clay and marsh mud and pieces of wood. The thickness of the layer covering the roofs is not clear and seems also

to have depended on the area. The interpretation which seems most sensible to me is that the first year when the casemate had been built, i.e. either 1752 or 1753, the layer above the casemate and the south arm of 2E20M was approximately 4' with a top elevation of approximately 131.0'-130' ASL. This level of soil extended to the well (the top surface being approximately 0.5' below the top of the well). The layer of soil above 2E20M's north arm would have been at least 2' (according to 67-37-D8, up to top of Soil 7, but perhaps more, so as not to make the slope too abrupt from the south arm of 2E20M; perhaps the surface was level with the roof on top of the curve in 2E20M's west wall, or slightly higher than this, approximately 129.5' ASL or higher. The following year perhaps, 1753 or 1754, but at any rate by 1755, if structures are French, otherwise later even, a new layer of dark reddish brown sandy loam (5 YR;3/4) bottom layer of layer 2 and layer 5 perhaps, was added over the whole bastion in order to form the parapets, the terrepleine, etc. Maybe this year or as soon as 2E20J and 2E20M had been built, 2E20L was constructed. This would mean that the drain of 2E20L had already been constructed before, though it may still have been in use. The well at this time is not being used, but is still above ground.

In 1755 the salient angle is heightened, and the traverses are placed on the flanks. The English take over. The Prince Frederick Bastion was presumably cleaned and repaired with the rest of the fort; perhaps at this time the southern face of the curve of 2E20L was added, or the casemate and 2E20M were constructed in present state.

In 1760 the forces were reduced to about two companies (Nadon:1966). The following year the traverses on the bastions, presumably Prince Frederick also, were still existent and timber casemates are extremely decayed--but no mention of 2E20J-M.

In 1766 some of the roofs of the timber casemates have fallen down; perhaps also at this time the roof of 2E20J-M had fallen down. In which case the bastion might have been filled at this time wherever depressions were caused. It is clear that the casemate had been cleaned out before it collapsed; it also must have demanded a considerable amount of manpower to fill in the cave-ins so that we should probably expect the cave-ins at least to have been filled at a time when the fort was occupied by soldiers. But the exact date does not seem possible to determine. Some time before 1779 a postern may have been built (Nadon: 1966), but there is no archaeological evidence for sure on this.

In 1812 a bomb-proof of stone was built somewhere in the fort. For reasons mentioned on P.41 I do not think this referred to 2E20J and M, but these reasons are not decisive.

The other possible interpretation of Prince Frederick Bastion would have the earth above the casemate immediately at the level of to-day's top soil. This would not explain the remains of sod on 67-37-D22 a and b, -D23 a and b, -D13 (Soil 6), and the lack of collapse patterns higher up.

One of the major problems of reconstructing Prince Frederick Bastion is the well, since it was still visible on the English plans. However I think that probably the earth would simply have sloped down towards the well, as would be natural since it is in the middle of the bastion. The well would have been filled after the cave-ins.

Later developments were the postern mentioned above, and a further collapse in the well which occasioned Soils 4 on 67-37-D5.

In general the structures of Prince Frederick Bastion agreed with the plans found in Nadon's report.

References

Encyclopaedia Britannica

1910

Cambridge University Press, Cambridge. Vol. VI

Frohn, Winnie

1967 Original Field Notes. 67-37. National Historic Parks and Sites Branch, Parks Canada, Ottawa.

Gay, C.M.

1932

Materials and Methods of Architectural Construction.

John Wiley and Sons, Inc. New York.

Korvemaker, E. Frank

1967

Excavation of Prince Frederick Bastion and Men's Barracks.

Manuscript Report Series No. 127, National Historic Parks and Sites Branch, Parks Canada, Ottawa.

Nadon, Pierre

1966

"Historical Report on Fort Beausejour." Manuscript on file, National Historic Parks and Sites Branch, Parks Canada, Ottawa.

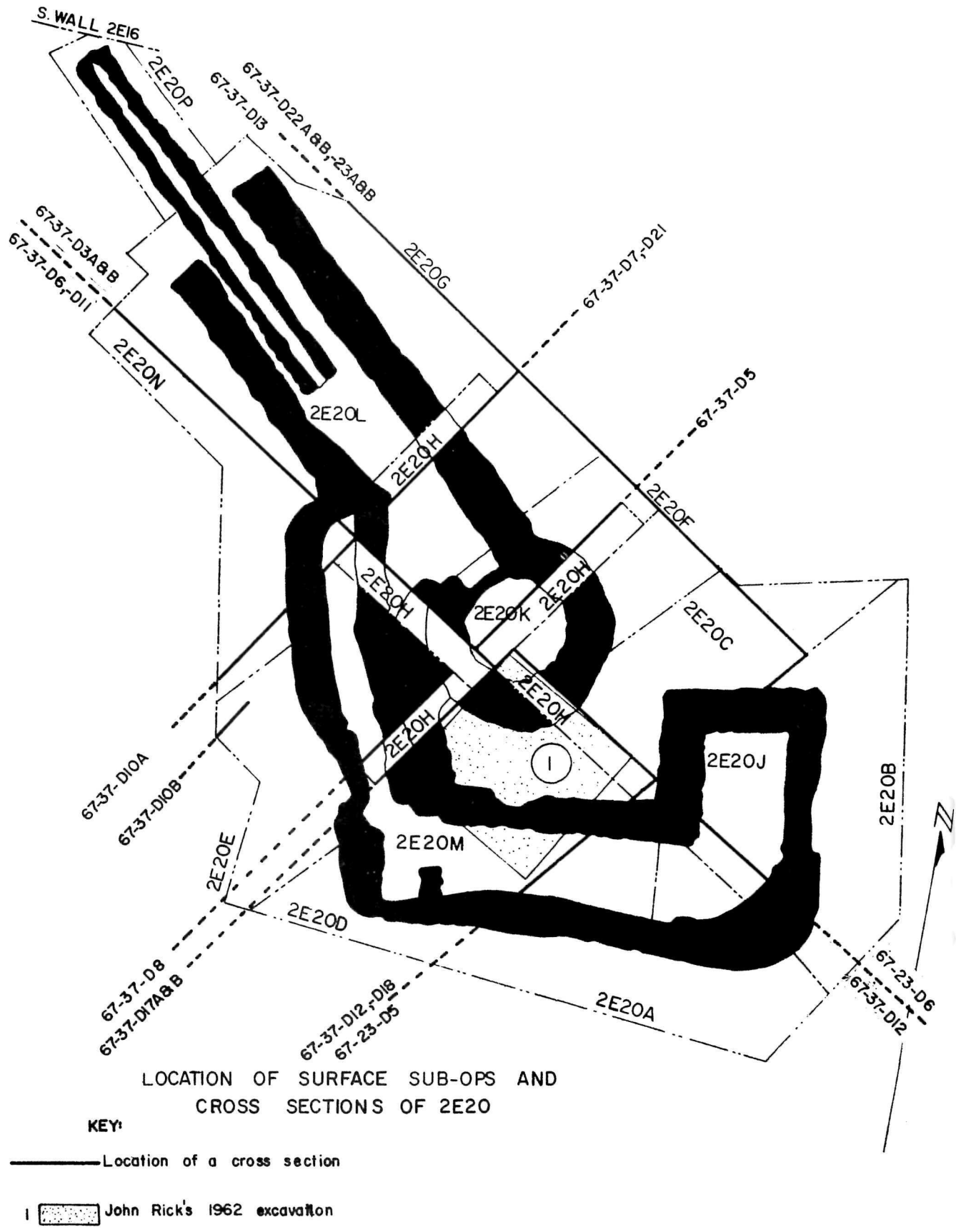

LOCATION OF SURFACE SUB-OPS AND
CROSS SECTIONS OF 2E20

KEY:

- Location of a cross section
- ▨ John Rick's 1962 excavation

SCALE: 1" = 10'

FIG. 1

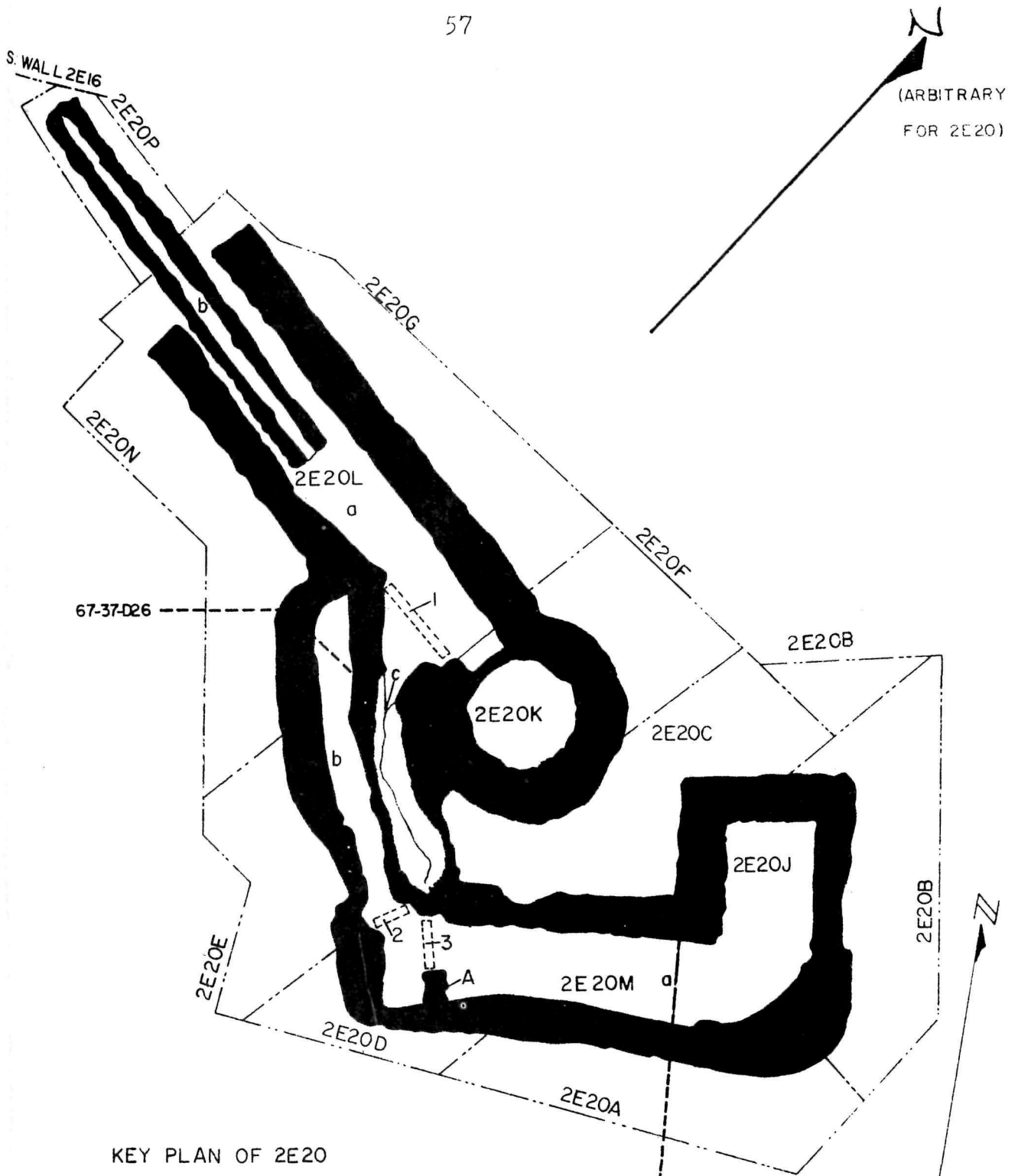

KEY PLAN OF 2E20

- A WALL A
- 2E20J CASEMATE
- 2E20M a SOUTH ARM OF CURVED PASSAGEWAY
- 2E20M b NORTH ARM OF CURVED PASSAGEWAY
- 2E20M c DRAIN
- 2E20K WELL
- 2E20L a STRAIGHT PASSAGEWAY
- 2E20P b DRAINWAY
- 1,2,3 DOOR SILLS
- CROSS SECTIONS

FIG.2

SCALE: 1"=10'

58

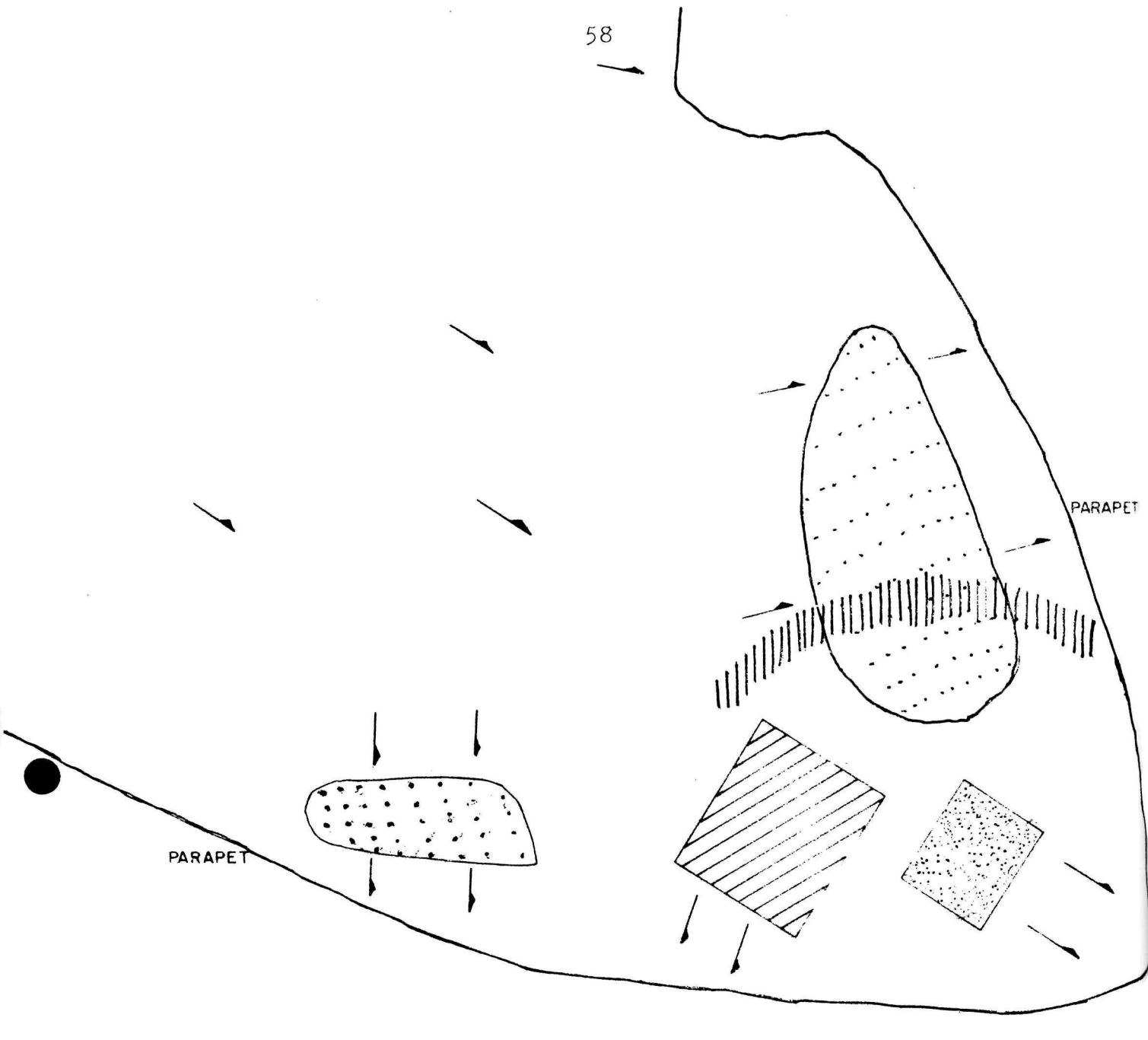





PARAPET

PARAPET

PRINCE FREDERICK BASTION
CONTOURS

KEY:

-  ELEVATED AREAS
-  TURF & TOPSOIL IS MISSING (CANNON BASE)
-  GRASS IS SPARSER & COARSER THAN ELSEWHERE
-  GRASS IS MISSING
-  POINTS TO HIGHER POINTS



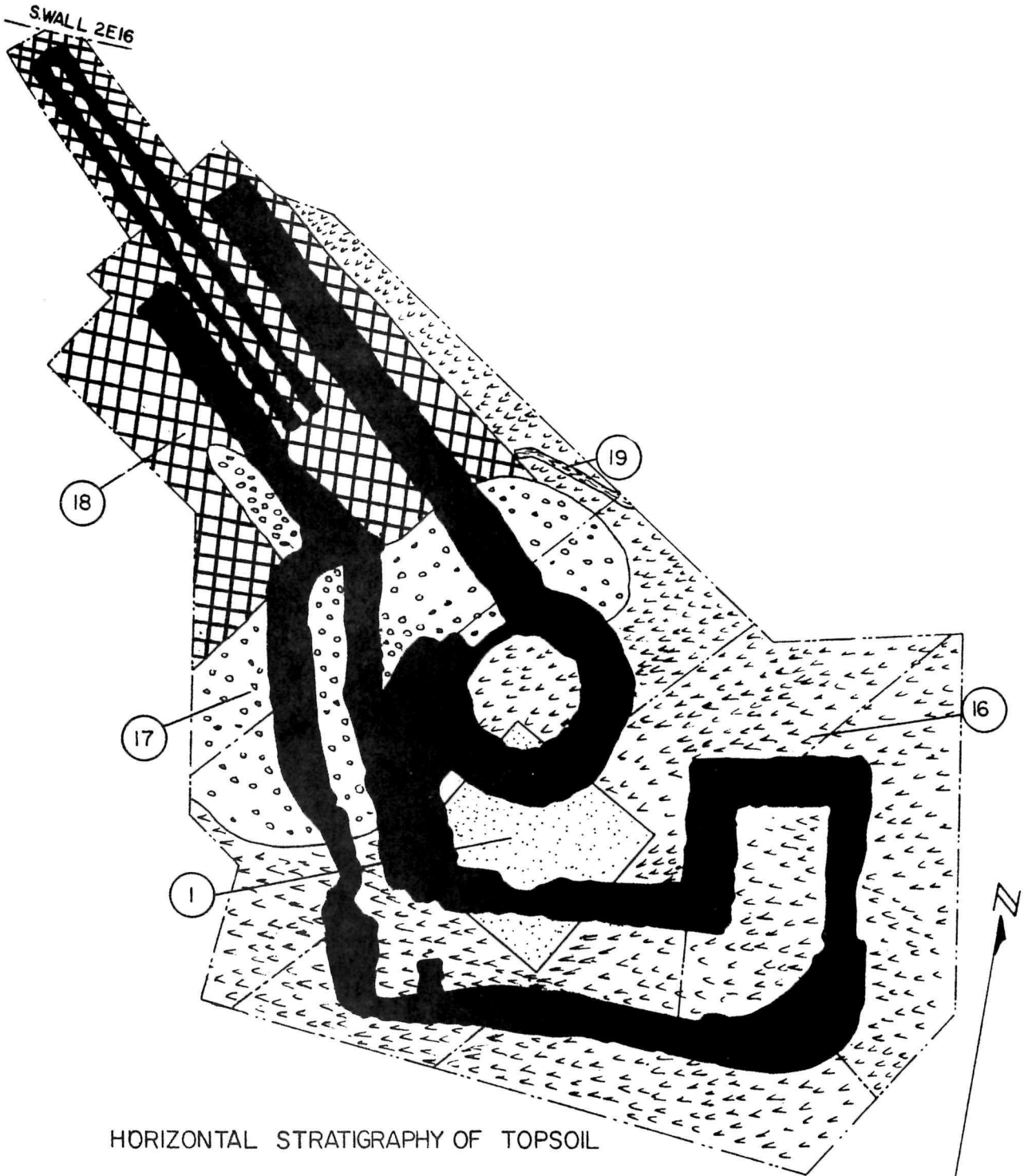

SCALE: 1" = 10'

FIG. 3



HORIZONTAL STRATIGRAPHY OF TOPSOIL

KEY: IN 2E20

- 16  Dark brown loam(75yr; 4/4)-eastern part of drawing
- 17  Dark reddish brown loam(5yr; 3/4)-middle part of drawing
- 18  Dark brown loam(75yr; 3/2)-western part of drawing
- 19  Wood & Spikes
- 1  John Rick's 1962 Test Trench(a mixture of soils)

SCALE: 1" = 10'

FIG. 4

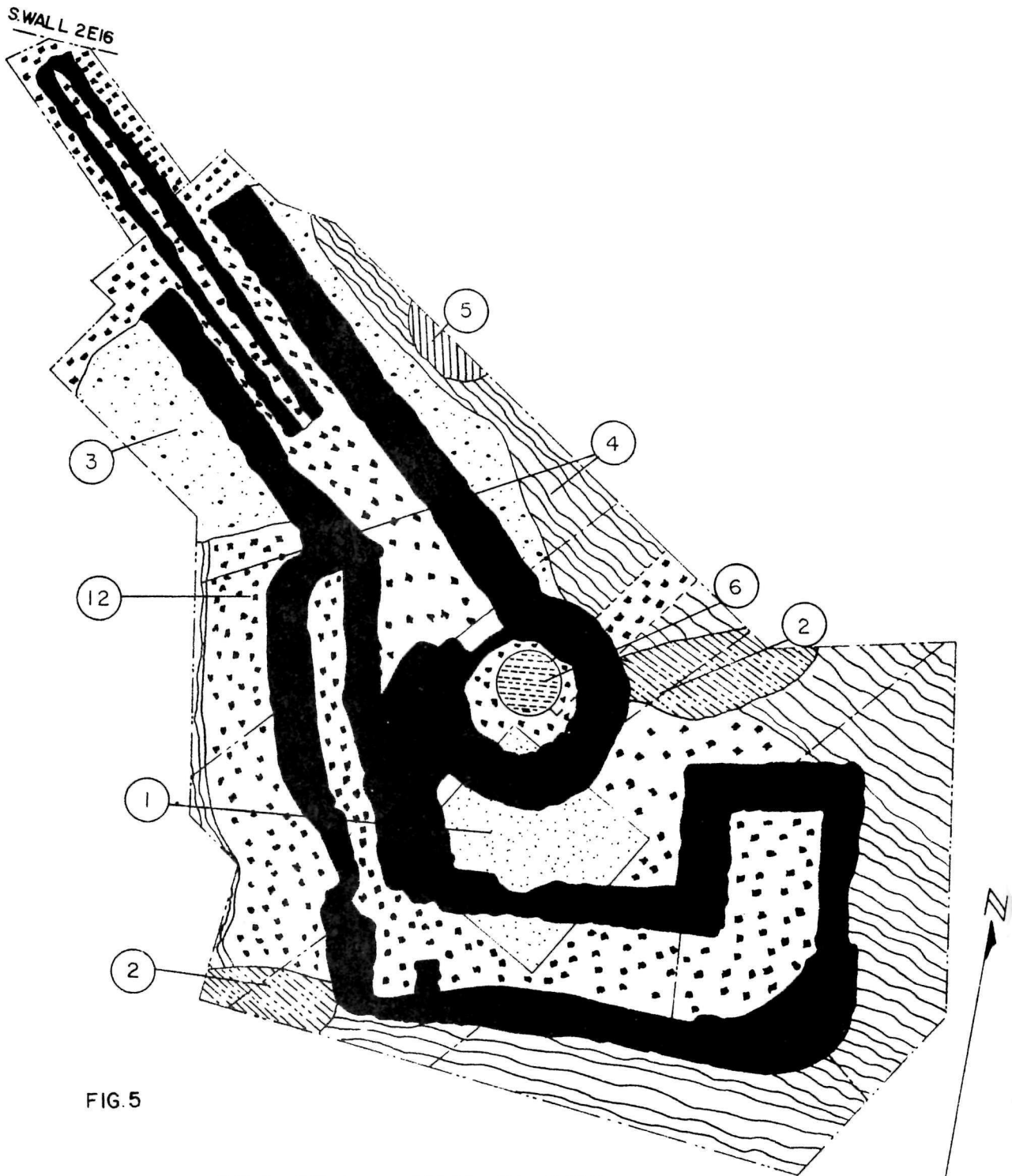

FIG. 5

SOILS BELOW TOPSOIL IN 2E20

KEY:

- 12 Dark reddish brown sandy loam (5yr; 3/4)
- 3 Dark brown silty loam (2.5yr; 4/4); dark brown sandy clay (7.5yr; 3/2) plus stones
dark brown sandy loam (7.5yr; 3/2) plus charcoal pieces; dark brown sandy loam (7.5yr; 3/2)
- 4 Dark brown sandy loam (7.5yr; 4/4)
- 5 Mixture of many soils (soils 10 on x-s: 67-37-22 A & B)
- 6 Mixture of soils (soils 4 on 67-32-D5)
- 1 John Rick's 1962 Test Trench
- 2 Rock pile

SCALE: 1" = 10'

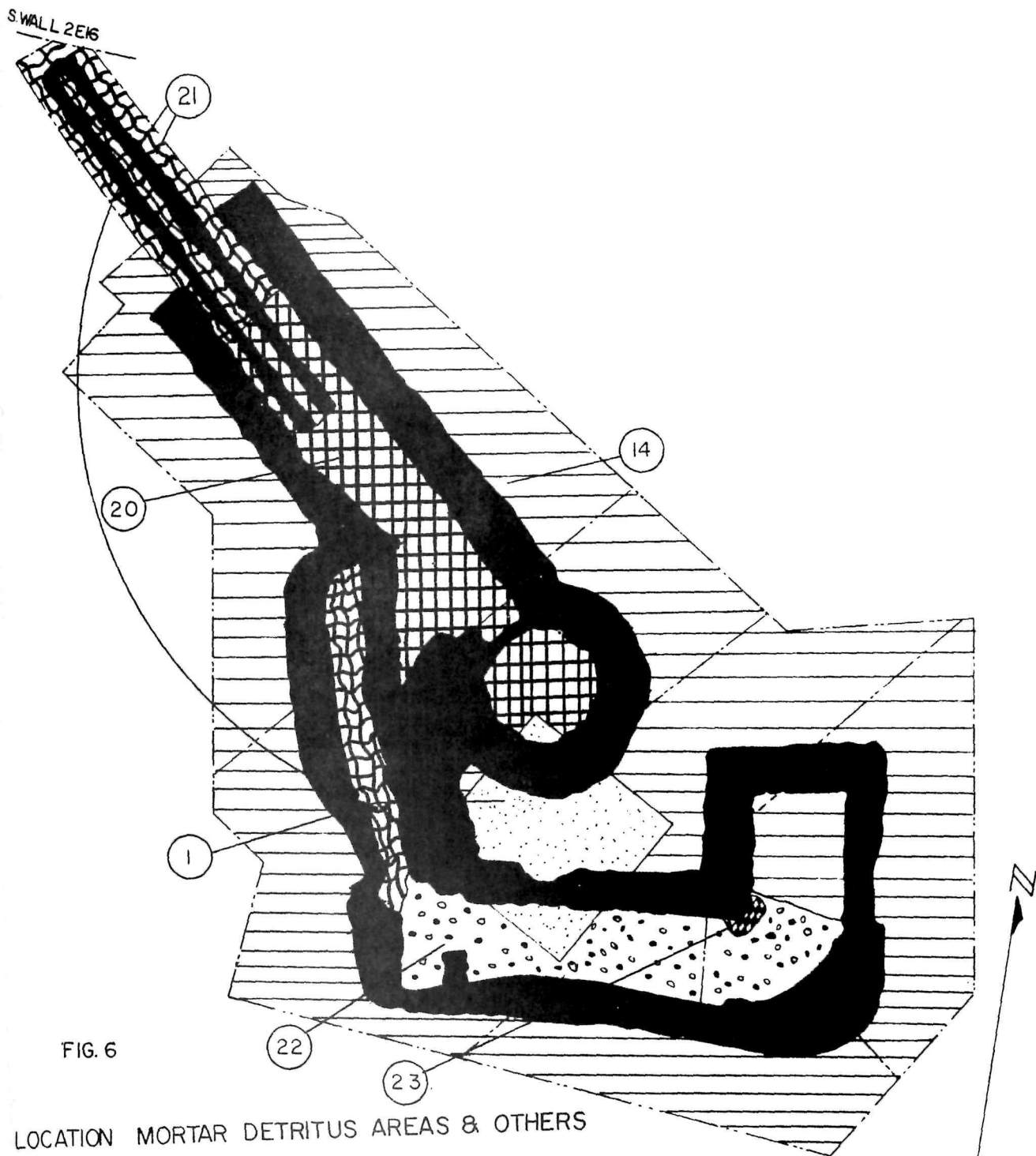

FIG. 6

LOCATION MORTAR DETRITUS AREAS & OTHERS
 BETWEEN ELEVATIONS OF APPROX. 132'-127' A.S.L.

- KEY:
- 20 Mortar detritus area
 - 21 Less concentrated mortar detritus area (thin layer, 0.01'-0.09') (underneath is dark reddish brown sandy clay (5yr; 3/4))
 - 1 1962 excavation: mixture of dark brown loam (7.5yr; 4/4), dark reddish brown sandy loam (5yr; 3/4), dark brown loam (7.5yr; 4/2), yellowish red sandy loam (5yr; 4/6), black loam (5yr; 2/1), dark reddish brown sandy clay (5yr; 3/4), & field stones
 - 14 Dark reddish brown sandy clay (5yr; 3/4)
 - 22 Mixture of dark reddish brown sandy clay (5yr; 3/4) & yellowish red loamy sand (5yr; 4/6)
 - 23 Concentration of nails & strong brown clay (7.5yr; 5/6)

SCALE: 1" = 10'

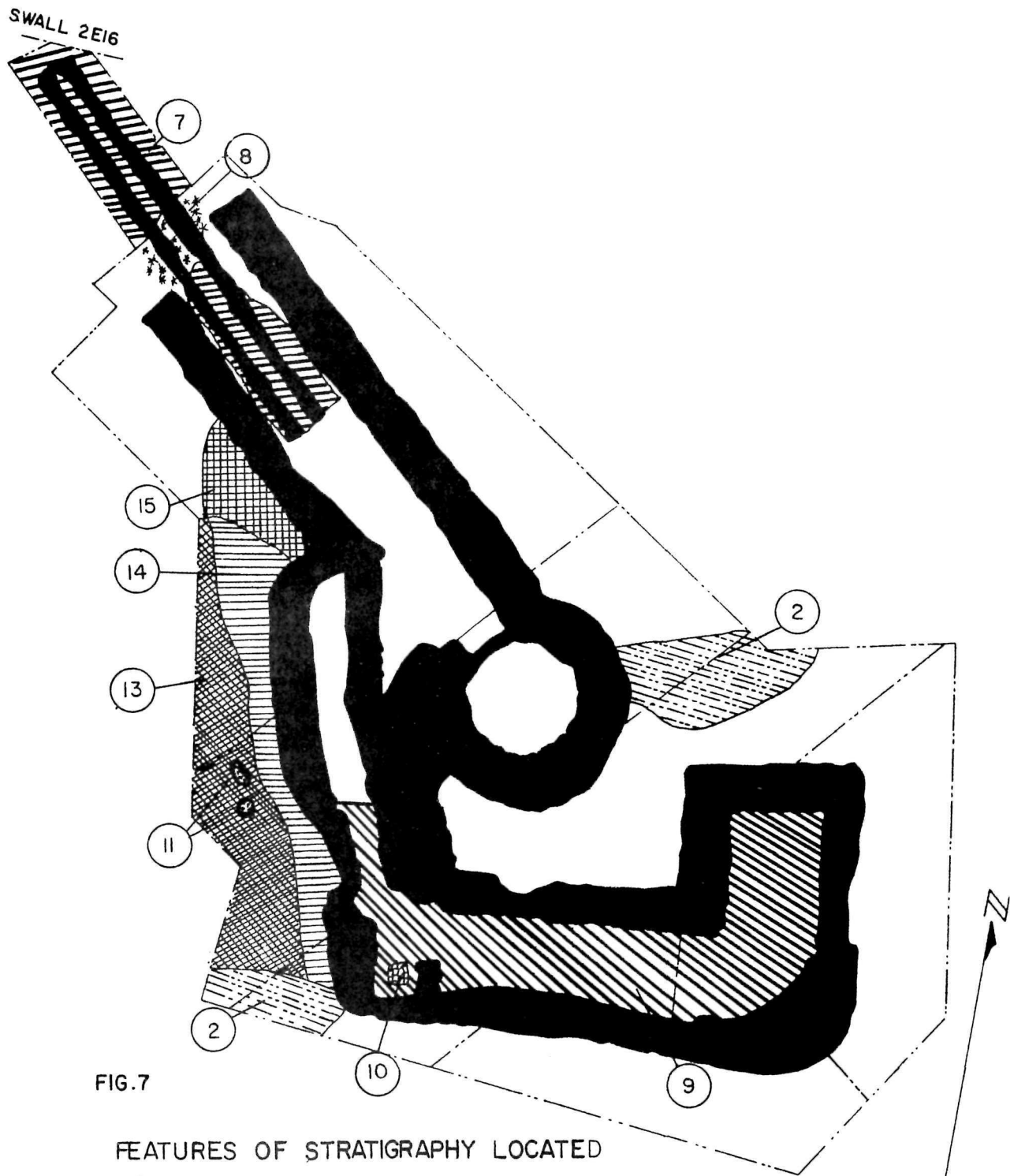











FIG.7

FEATURES OF STRATIGRAPHY LOCATED

KEY:

IN 2E20

- 7  2E20LI-Coal ash layer
- 8  Very thin layer of coal ash
- 9  Dark brown sand(7.5yr; 4/4)-on top or between cobble stones in or at floor level
- 10  Pit dug below sand to reddish brown sandy clay(5yr; 4/3)
- 11  Wood & charcoal post moulds
- 13  Dark brown loam(10yr; 4/4) & reddish brown clay(5yr; 4/3)
- 14  Dark reddish brown sandy clay(5yr; 3/4)
- 15  Dark brown sandy clay(2.5yr; 3/2)
- 2  Rock pile

SCALE: 1" = 10'

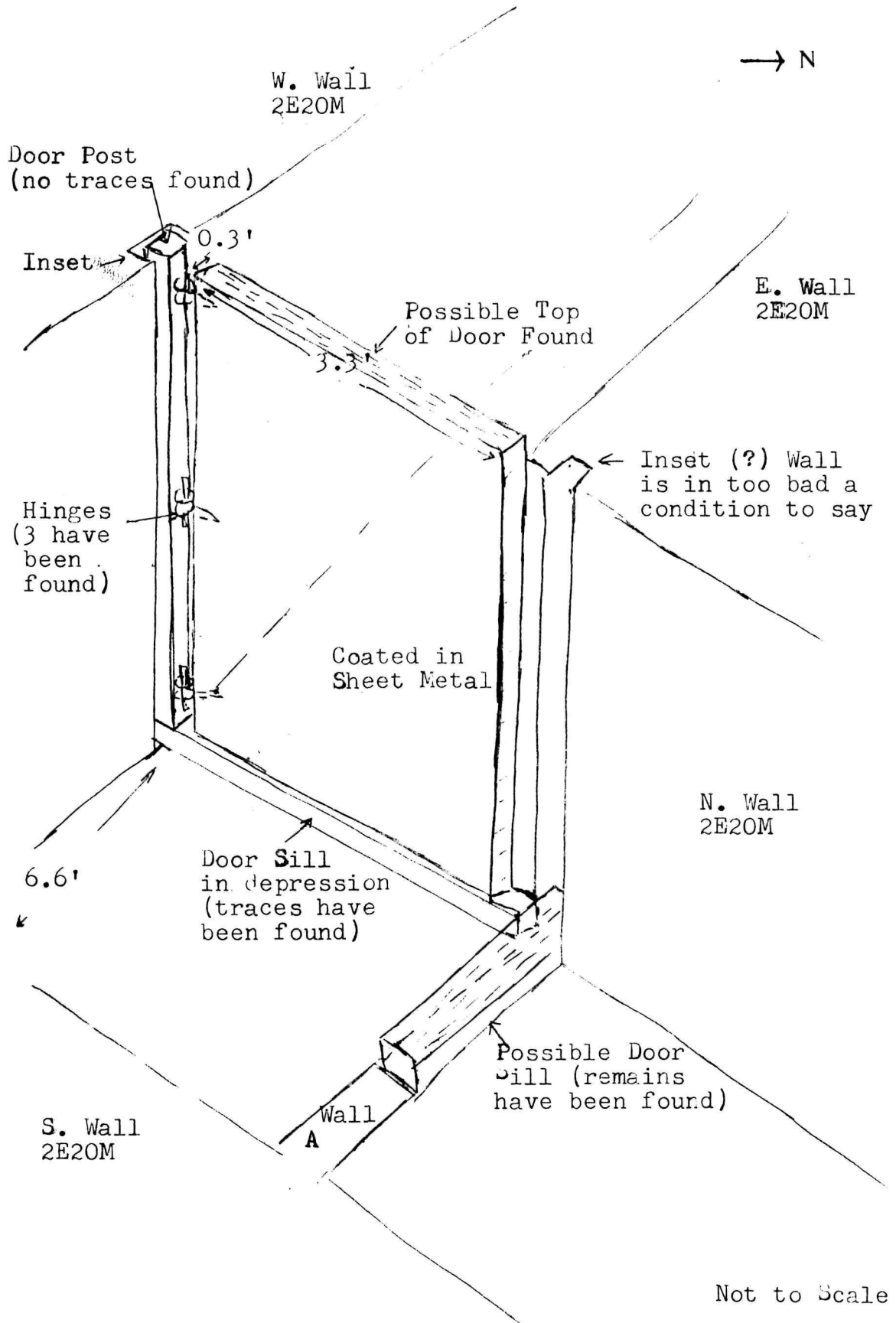
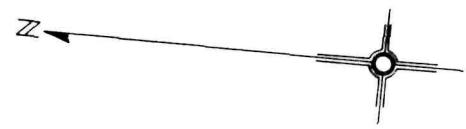
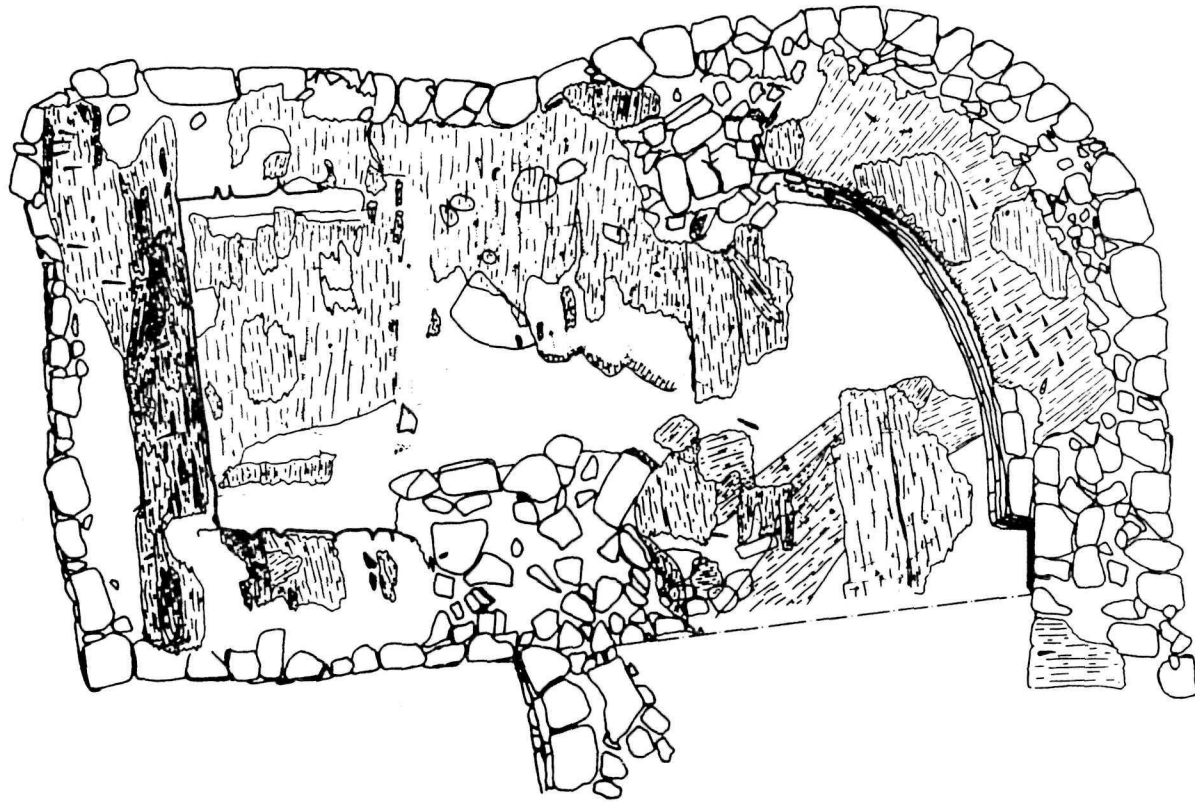

Fig. 8 Reconstruction of possible door (2E20M8).

Fig. 9 Plan of 2E20J roof (2E-67-102-12).



FORT BEAUSEJOUR N.B. SITE 2E

CASEMATE ROOF PLAN
SUB-OPERATION 2E20J

A scale bar showing a length of 5 feet, divided into 5 equal segments of 1 foot each.

LEGEND

WOOD	STONE
NAILS	KNOTS
EXCAVATION LIMIT	LOWER LEVEL WOOD & GRAIN DIRECTION
	LOWER LEVEL STONE

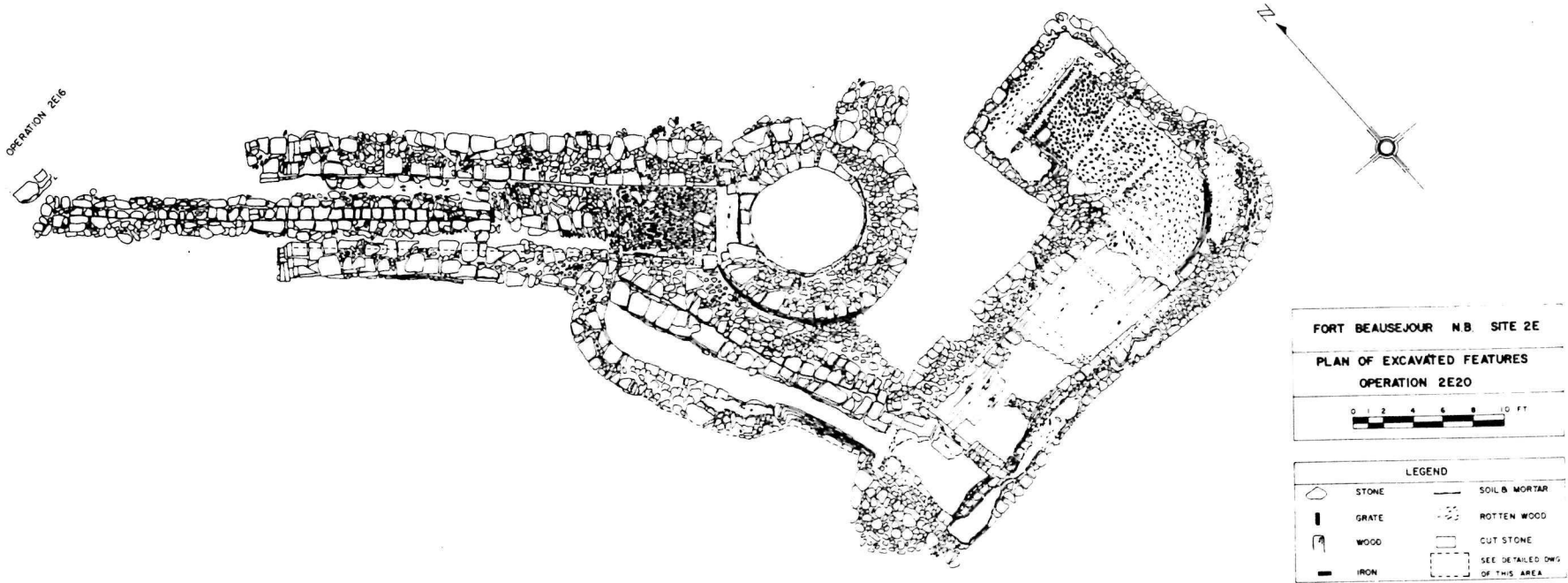

Fig. 10 Plan of 2E20 excavation (2E-67-105-11).

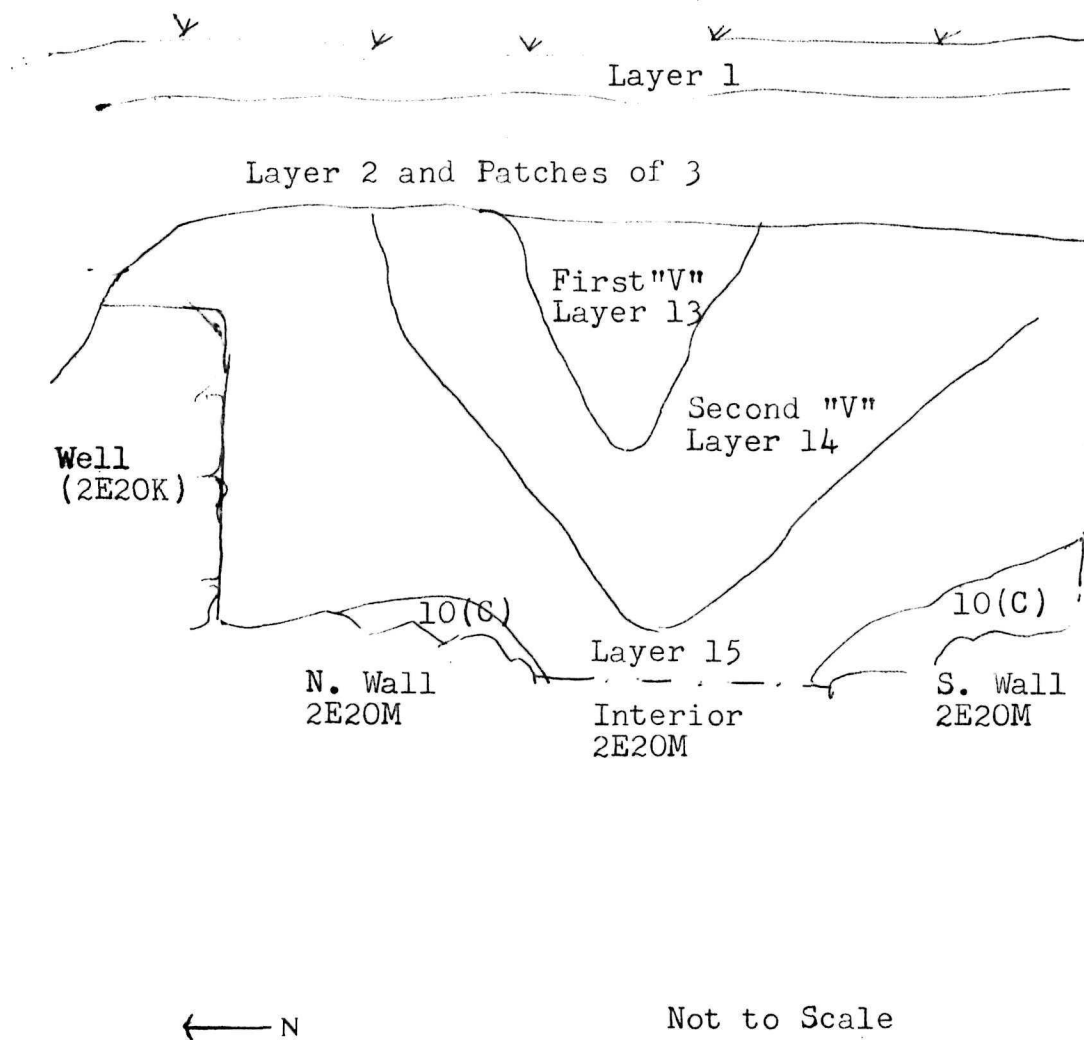

Fig. 11 Diagram of "V" of layers 13 and 14 above south arm of 2E20M.



Fig. 12:(2E-173 X)

At the bottom of the mortar layer at the entrance to 2E20M from 2E20L. Camera is facing southeast. Scale: 6' rod. Notice abrupt end of layer to the south, gradually sloping north and down.

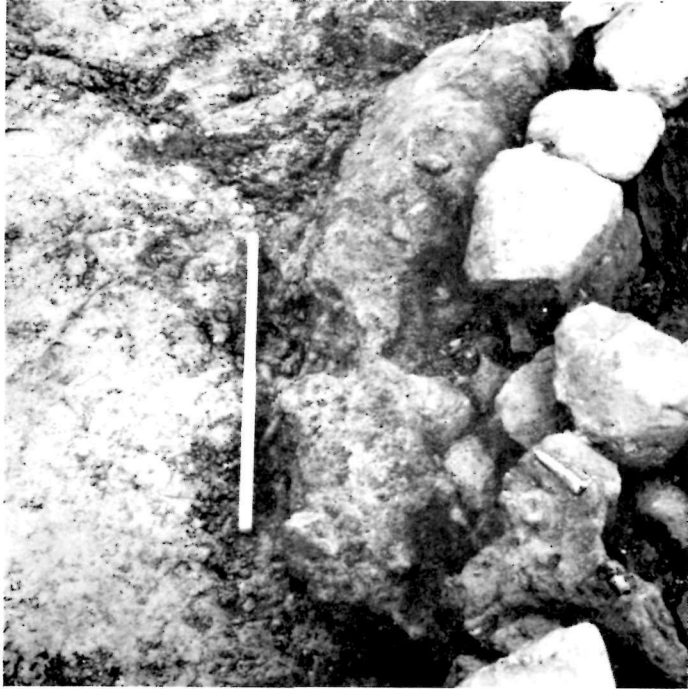

Fig. 13a: (2E-270 X).
 First layer of soil stain and nails at 2E20J-M.
 junction. Camera is facing southwest. 2' scale.
 A is north wall of 2E20M; B is west wall of 2E20J.



Fig. 13b: (2E-455 X)
 Second layer. Camera facing northeast. 2' scale.



Fig. 14: (2E-464 X)
The casemate (2F20J) showing remains of
wooden roof. Camera is facing north. 8'
scale.



Fig. 15: (2E-622 X)
The drain (A); the west wall of 2E20M in back-
ground and the continuation of the east wall
of 2E20M to the left. Camera is facing west. 3'
scale.



Fig. 16: (2E-697 X)
The top of the door of Sill #2 on Fig. 2. The camera is facing northeast. 2' scale.



Fig. 17: (2E-621 X)
The north end of the west wall 2E20M. The north
arrow is 0.5' long. Camera is facing southwest.

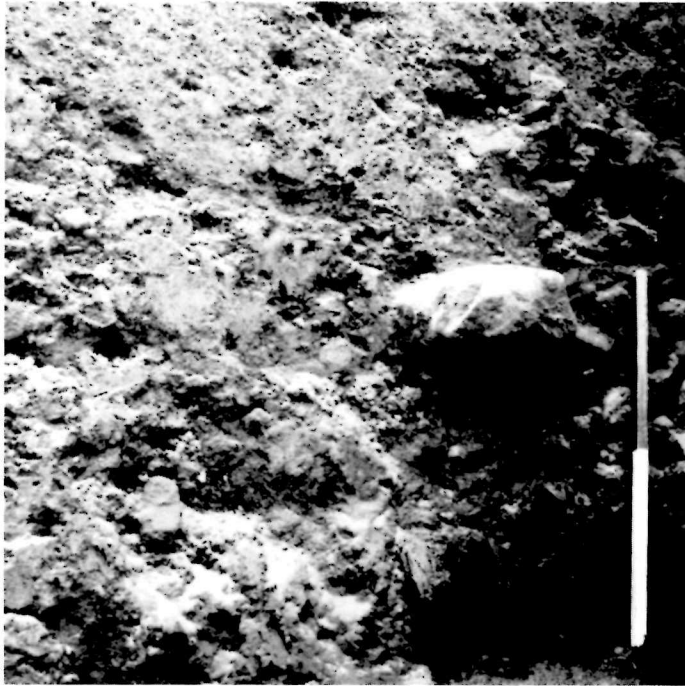

Fig. 18: (2E-382 X)
Example of the remains of the palisade found. 2'
scale. Camera is facing south. Palisade is in the
south wall of 2E20A.



Fig. 19: (2E-462 X)
The north part of the casemate 2E20J. The interior still has wooden roof remains. Camera is facing west. 8' scale. North wall; most of east and west walls extant to original height.



Fig. 20: (2F-461 X)
Remains of wooden roof on south wall of
2F20M. 2' scale. Camera is facing down and
slightly north.



Fig. 21: (2E-539 X)
The casemate 2E20J. Notice the third "face"
of the curve. 8' scale. Camera is facing
south. Arrows indicate curve.

Table 1: Lot Layer Correlation

Turf & topsoil:	Layers 1 & 2:	2E20A1,2,3
		2E20B1,2,5
		2E20C1,2,3,5,6
		2E20D1,2
		2E20E1
		2E20F1,2,12
		2E20G1,2,8,9,10,14,19,20,26,27,28,29,32
		2E20H1,3,4,10,12,19,20,24
		2E20N1,2,9,10
		2E20P1,2
	Under topsoil:	Layer 2:
		2E20E6,7
		2E20G3,10,12,13
		2E20H5
		2E20N4,6,7
Under topsoil:	Layers 13-16:	2E20A4
		2E20D3
Layer 5b:		2E20G6,21,25,31
		2E20H23
Layer 5a,b:		2E20F6
Layer 5:		2E20G11
		2E20N3,11
Layer 3:		2E20D4
		2E20F5
		2E20G5,15,22
		2E20H6,21

	Layer 3:	2E20N5
	Layer 4:	2E20F9 2E20H7,22
	Layers 19 & 20:	2E20G7,24
Turf to base of excavation	Layers 1,2,10:	2E20A6 2E20D5 2E20E9
Turf to base of excavation Lots below tops of architectural features, 2E20J & 2E20M	Layers 10c,16:	2E20A5 2E20c8 2E20J1,2,3 2E20M1,2,4,5
	Layer 16:	2E20J6,7
	Layer 12:	2E20J8 2E20M3,6,7,9
	Soil stain:	2E20J4
	Door & artifacts:	2E20M8
	Casemate roof:	2E20J5
Lots below top of architec- tural feature- 2E20L	Layer 6a:	2E20G30 2E20L1 2E20P3
	Layer 6b:	2E20G17 2E20L2 2E20P4

Layer 9: 2E20P5,7

(drain area)

2E20X2- J.H.R. 1962 trench, re-excavated

Not listed: Layers 7,8,11,12,17

Table 2: Roofs of 2E20J and 2E20M

Sub-op:	2E20J	South Arm of 2E20M	North Arm of 2E20M
Photos:	Fig.11,16	Fig.17	- -
Drawings	Casemate Roof Plan (Fig. 9)	Plan of Excavated Features 67-37-239, 252 67-37-297 (Polaroid)	Plan of Excavated Features 67-37-181, 289, Polaroid: 67-37-266
Thicknesses:			
1st layer:	from 0.04' to 1' 0.07' to 0.25' (usually 0.1')	average thickness: 0.03' av: 0.1', from 0.02' to 0.2'	- - - -
earth	reddish brown sandy clay (5 YR;4/3) or dark reddish gray sandy clay (5 YR;4/2) approx. 0.07' thick	approx. 0.15'	
width	approx. 0.65' split logs or planks) for 1st layer same for 2nd layer	0.65' to 1' (usually planks) for 1st layer same for second layer	average: 0.5'

Table 3: Walls of 2E20J and 2E20M

Sub-op	2E20J	south arm of 2E20M	north arm of 2E20M
Photos	Fig. 18, 16		
Widths	Av. width <u>except for curved part</u> , and incomplete parts: 2.8' curve: 3.5'-4' (a-long diameter)	<u>n.wall</u> : av:2.7' (where complete) <u>s.wall</u> : av: 2.1'	W.wall:av: 2.2' e.wall:av: 2.3' (perhaps, wall is in bad state)
Courses (interior) to floor where complete	<u>east wall</u> : 5 & one thin course (0.3') at top. <u>n.wall</u> : 8 at N/W corner, 5 at N/E corner w.wall: 8-9 courses curve: 8 & thin course (0.3') at top.	<u>n.wall</u> : 1-2 (above is rubble) <u>s.wall</u> : 9 <u>Wall A</u> : 9	<u>w.wall</u> : 8 except in curved part, here there are 10. e.wall: no courses <u>e.wall</u> : no courses could be seen.
Elevations: top: A.S.L.	<u>e.wall</u> : interior: north corner:I27.65' at curve:I27.55' <u>exterior</u> : north corner:I27.85' at curve:I27.25' <u>n.wall</u> : interior:	<u>n.wall</u> : exterior: at n.arm:I27.85' <u>s.wall</u> : interior: at WallA: I27.5' in S/W corner:I27.5' 20' from interior <u>exterior</u> at wall A: covered by	w.wall: interior: at junction with 2E20L: I27.92' near highest point in curve: I30.2' s/w corner of 2E20M (I.E. end of curve):

west corner:128.75'	earth	127.6'
exterior:	in S/W corner:127.11'	exterior was not un-
west corner:128.75'	<u>Wall A:</u>	covered except for
exterior:	av elevation:127.2'	the curve, where
west corner:128.4'	(where complete)	elevations for
for east end of		exterior are same as
north wall refer to		interior.
north end of east wall		<u>e.wall</u>
<u>w.wall</u>		interior and exterior
at 2E20M:128.85'		elevations are approxi-
(exterior)		mately the same.
<u>curve:</u>		at juncture with w.wall
interior:		124.55'
at w. end:127.55'		beside well and 2E20L:
exterior:		124.88'
at w.end:127.25'		in line with southern
		point of well: 125.75'
		at s.arm: 127.85'
bottom:	<u>e.wall:</u>	<u>w.wall</u>
A.S.L.	interior:	interior:
north corner:122.95'	at n.ram:122.3'	at junction with 2E20L,
at curve:122.75'	exterior: (from	bottom is in top of
<u>n.wall</u>	John Rick's 1962	what was the east wall:
interior:	notes:	124.55'
west corner:122.75'	62-1-141-2)	
	at juncture with 2E20J:	

Table 3: Walls of 2E20J and 2E20M (cont'd)

Sub-op: 2E20J	south arm of 2E20M	north arm of 2E20M
<u>w. wall</u>	at bottom of plinth:	<u>w. wall</u> (cont'd)
INTERIOR:	122.48'	on top of drain: 123.7'
at 2E20M: 122.95'	at top of plinth:	s. of drain: 122.2'
<u>curve:</u>	123.60'	<u>e. wall:</u>
interior:		at juncture with w. wall:
at west end: 122.65'	at juncture with n. arm:	123.7' (on top of drain)
	at bottom of plinth:	beside well and 2E20L:
	122.425'	123.02' (on drain)
	at top of plinth:	
	123.51'	
	<u>s. wall:</u>	
	interior:	
	at Wall A:122.4'	
	in s/w corner: 122.7'	
	<u>Wall A:</u>	
	bottom wl.:122.4'	

Table 4: corners of 2E20M

Sub-op: 2E20J	south arm of 2E20M	north arm of 2E20M
bonded: n/w (but not regularly alternating) n/e (regularly alternating)	Wall A is bonded in top course, otherwise abutting.	what was the east wall goes under w. wall (refer to Fig. 12) w. wall may have been bonded with 2E201 but it is not in good enough condition to sure. (Refer to Fig. 14)
abutting: curve abutts onto the exterior curve, i.e., the first layer facing interior of 2E20J is abutted onto rest of wall.		
	corner joining the south and north arm of 2E20M could not be seen clearly because in the north arm of 2E20M's east wall, no courses of stone could be distinguished.	

Table 5: Dimensions of Bricks in 2E20

length	width	thickn.	2E20G27	2E20H6	2E20L2	2E20M3	2E20M6	Total
0.6'	0.3'	0.14'	1					1
0.6'	0.31'	0.15'		1				1
0.61'	0.3'	0.14'		2				2
0.6'	0.29'	0.13'		1				1
0.62'	0.31'	0.14'		1				1
0.59'	0.29'	0.15'		1				1
0.6'	0.29'	0.13'		1				1
0.63'	0.3'	0.15'			1			1
0.6'	0.29'	0.15'				2		2
0.62'	0.3'	0.15'					1	1
0.6'	0.3'	0.15'					1	<u>1</u>
								<u>13</u>

2E20GI5 had a brick pile, but no whole bricks: widths of bricks varied from 0.28' to 0.36'; thickness varied from 0.15' to 0.18'

2E20G27, 2E20H6, and 2E20GI5 are all above the structures.

2E20L2, 2E20M3, 2E20M6 are all within the structures.

Appendix 1: 2E16 (from notes of 1967 season)

Bricks removed from the exterior of 2E16:

Length (')	width(')	thickness (')	Number (bricks)
0.58	0.29	0.15	18
0.6	0.3	0.16	5
0.56	0.28	0.15	7
0.59	0.28	0.15	1
0.55	0.28	0.15	15
0.62	0.3	0.13	1
0.59	0.27	0.18	1
0.58	0.27	0.15	1
0.6	0.31	0.15	1
0.61	0.32	0.17	3
0.58	0.29	0.17	1
0.57	0.28	0.13	1
0.57	0.29	0.16	4
0.6	0.3	0.17	2
0.68	0.31	0.2	4
0.58	0.27	0.14	1
0.56	0.28	0.12	2
0.56	0.28	0.14	1
0.54	0.27	0.15	3
0.6	0.3	0.15	2
0.6	0.3	0.16	7
0.59	0.3	0.14	10
0.58	0.31	0.16	1
0.6	0.3	0.17	4

Bricks removed from the exterior of 2E16:

Length (')	width (')	thickness (')	Number (bricks)
0.55	0.27	0.17	3
0.6	0.32	0.17	1
0.58	0.3	0.18	1
0.6	0.28	0.17	1
0.58	0.28	0.17	2
0.6	0.3	0.14	2
0.57	0.3	0.15	1
0.57	0.28	0.16	3
0.58	0.31	0.14	4
0.59	0.3	0.15	1
0.61	0.3	0.15	2
0.58	0.3	0.18	1
0.6	0.29	0.16	1
0.61	0.3	0.15	3
0.58	0.28	0.15	2
0.62	0.31	0.17	1
0.55	0.3	0.16	2
0.58	0.3	0.17	3
0.59	0.28	0.2	1
0.67	0.3	0.2	1
0.63	0.3	0.17	1
0.6	0.25	0.15	1
0.65	0.31	0.21	1
0.61	0.3	0.18	1

total: 151

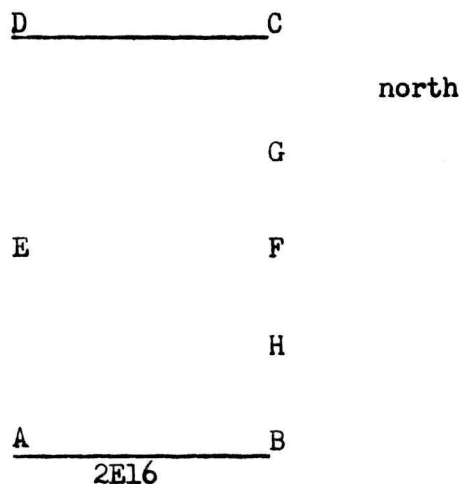

Corners of 2E16

A: bonded

B: "

C: brick pattern is in the way

D: bonded

E: abutted

F: bonded (but many stones missing)

G: abutted

H: I could not see clearly enough.

Bricks removed while cleaning 2E16

length (')	width (')	thickness (')	number (bricks)
0.3	0.6	0.15	36
0.3	0.56	0.18	1
0.3	0.6	0.13	1
0.31	0.63	0.17	1
0.3	0.64	0.19	1
0.3	0.58	0.15	10
0.3	0.55	0.15	6

Length (')	width(')	thickness(')	number(bricks)
0.32	0.6	0.15	36
0.3	0.56	0.18	1
0.3	0.6	0.13	1
0.31	0.63	0.17	1
0.3	0.64	0.19	1
0.3	0.58	0.15	10
0.3	0.55	0.15	6
0.32	0.56	0.16	1
0.3	0.68	0.2	5
0.26	0.55	0.15	1
0.32	0.62	0.15	2
0.3	0.6	0.17	1
0.32	0.66	0.2	4
0.32	0.68	0.2	22
0.3	0.68	0.21	15
0.32	0.68	0.21	1
0.32	0.73	0.18	1
0.3	0.65	0.2	7
0.3	0.65	0.16	1
0.3	0.65	0.2	1

2E16K5(67-37-106)

A sword blade was found in this lot, situated at 3' south of the central wall of 2E16, 2.5' west. of the east limit of the excavation at an approx. depth of 1.5'

max. width: 0.1; length: 1.5'

max. thickness of blade: 0.01

" " " iron shaft (which goes into handle): 0.03'

At .6' from the point it has been broken. The point itself is bent.

It was found among the bricks to the east of the actual barracks.

The 1967 Excavation in the Prince Frederick Bastion
and Men's Barracks at Fort Beausejour

by E. Frank Korvemaker

LIST OF ILLUSTRATIONS

A. PRINCE FREDERICK BASTION (2E20).

FIG. 1:	Plan of Fort Beausejour No. H.M. 15414 (dated 1755-1778) showing a Casemate, Well, and two Passageways in the Prince Frederick Bastion	2
FIG. 2:	Plan of Original Excavation Limits plus Anticipated Structures	4
FIG. 3:	Plan of Final Excavation Limits plus actual Structures.	5
FIG. 4A:	Contour Map of the Prince Frederick Bastion before excavation.	8
FIG. 4B:	Contour Map of Prince Frederick Bastion with Excavated Structures Superimposed.	9
FIG. 5:	Stratigraphic Section through Prince Frederick Bastion from N - S. (Sub-ops. 2E20 C, D - H).	11
FIG. 6:	Stratigraphic Section of West Face of 2E20F.	13
FIG. 7:	2E20L - Photo of Vertical Stones forming Possible "arch" near the entrance of the Straight Passageway with part of the collapsed passageway walls behind it and Quoin stones at the entrance.	19
FIG. 8:	Stratigraphic Drawing through Prince Frederick Bastion from E - W (Sub-ops. 2E20 A, D, F, G - H).	21
FIG. 9:	Stratigraphic Drawing of East Face of 2E20F.	25
FIG. 10:	2E20K - Photo of Well Entrance (north side) showing break in the construction plus stone slot.	28
FIG. 11:	2E20K - Photo of Well Entrance (south side) showing break in the construction plus stone slot.	28
FIG. 12:	Drawing of Rounded Stones used for the Well (2E20K) and of Squared Stones used for the Straight Passageway (2E20L)	29
FIG. 13:	2E20L - Photo of abutted Joint between the North passageway Wall and the Well Entrance	32
FIG. 14:	2E20L - Photo of the Straight Passageway Entrance showing stones jutting out by the Interior Face of the North Wall.	32
FIG. 15:	2E20L - Photo of west half of Cobblestone Floor with metal section by stone sill in bottom left corner.	38

FIG. 16:	2E20L - Photo of east half of Cobblestone Floor with the Well Entrance in the foreground.	38
FIG. 17:	2E20P - Photo of the Drain in the Straight Passageway looking East	41
FIG. 18:	Drawing of the Gun Platform or Traverse found in 2E20F.	45
FIG. 19:	Reconstruction View of the Passageways, Well and Casemate in the Prince Frederick Bastion, looking East	52
B. MEN'S BARRACKS		
FIG. 20:	2E16B - Photo of Oven Front in Room I of the Men's Barracks	55'
FIG. 21:	Plan of North half of Men's Barracks showing location of Sleepers Beams in Rooms I and 3.	56
FIG. 22:	2E16T4 - Photo of Brick Feature found in this Test Trench.	60
FIG. 23:	2E16U4-U5 - Photo of Wood Beam plus Exterior Face of West Wall of Men's Barracks in this Test Trench.	60
FIG. 24:	Stratigraphic Drawing of North Face of 2E16U.	63

LIST OF TABLES

TABLE I	- Lot-Layer Correlation for the Straight Passageway (2E20L) and Well (2E20K).	68
---------	---	----

PREFACE

From May to September, 1967, I assisted Miss Winnie Frohn in directing excavation operations in the Prince Frederick Bastion, and conducted sub-floor tests in the Men's Barracks at Fort Beausejour, Aulac, N.B. The following men helped excavate these two areas:

Jim Cousins	Dave Rogerson
Willis Goodwin	Dean Scopie
Leo Hachey	Murray Scott
Ron Legere	Seymour Sears
Ron Murphy	Roland Wells

As this was my first season of excavation, much assistance, encouragement, and many suggestions were given by Jervis D. Swannack Jr., the director of the excavation, and by DiAnn Herst, his chief assistant, for which I am truly grateful.

CHAPTER I

PRINCE FREDERICK BASTION - INTRODUCTION

Excavation was carried out in the Prince Frederick Bastion to uncover the remains - if any - of a well, casemate, and two passageways. These are believed to have been constructed in this bastion between 1755 and 1778, as an undated map of that time period indicates (Fig. 1). At the end of the excavation season, we had found the above-mentioned structures - all of which were constructed of stone - plus two stone drains and portions of a wooden palisade and possible gun platform or traverse.

My particular area of excavation concerned the well (sub-op. 2E20K), the straight passageway (2E20L), and the stone drain inside of this passageway (2E20P). These three structures will be discussed in detail in Chapter III, showing a relationship between the various structures through a comparison of their architecture.

Chapter II will deal primarily with the stratigraphic aspect of the excavation. In this section the present stratigraphy will be outlined and an attempt will be made to show how, and, if possible, when it developed its present formation.

In determining a plan of excavation for this bastion, several factors had to be taken into consideration. First, and foremost, calculations had to be made concerning the most likely locations for the anticipated structures. Since no visible surface formations were apparent prior to the excavation which could help in this task, the decision where to place the trenches was made largely on the basis of original maps of the bastion and on John Rick's 1962 excavation which uncovered part of the well and L-shaped passageway walls. (62-1-119).

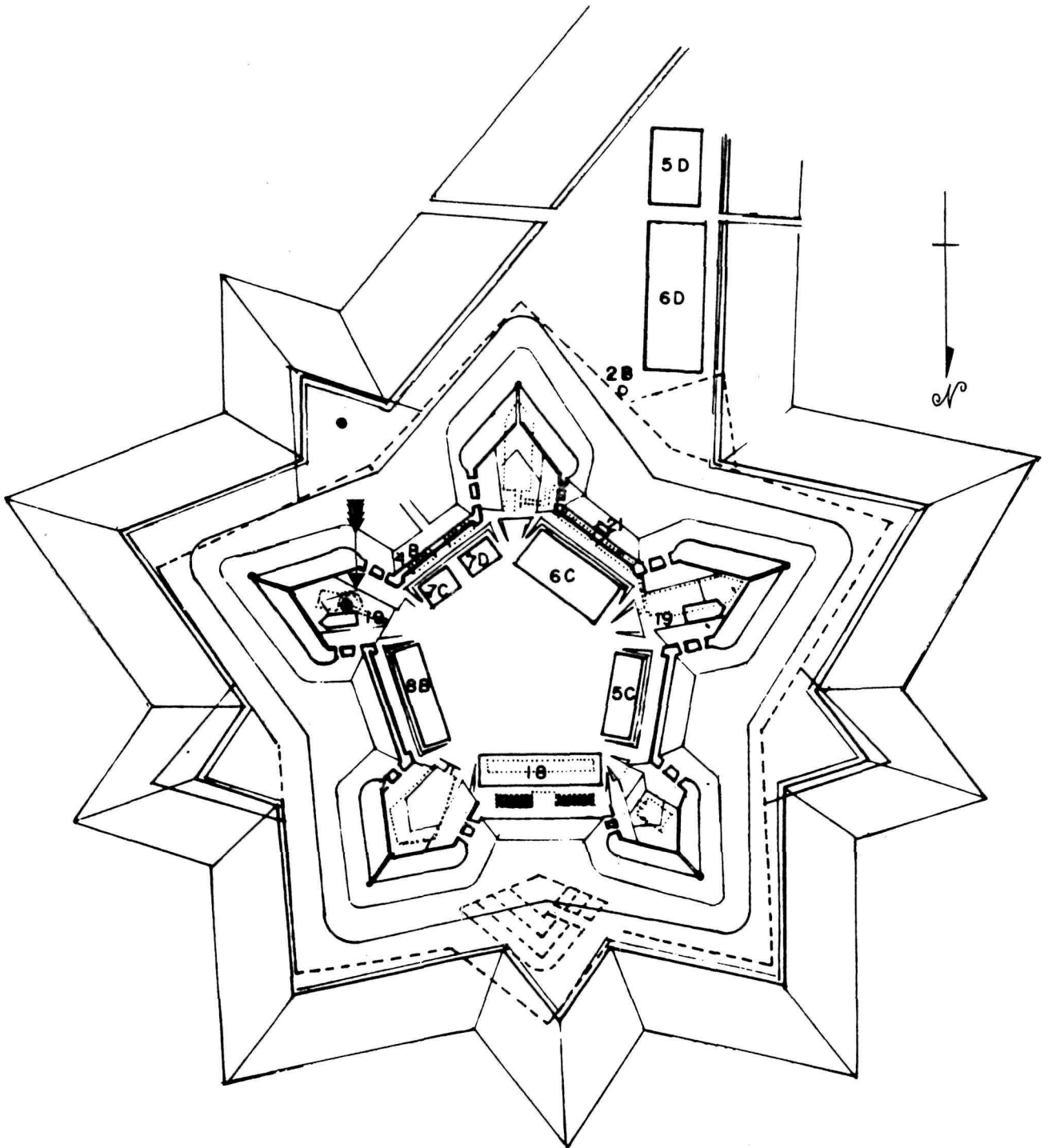

1 British plan of Fort Beauséjour (1755 - 1778) showing a casemate, well, and two passageways in the Prince Frederick Bastion. No scale.

Once the location of these structures was theoretically determined, seven trenches were staked out in the gorge of the bastion (sub-ops. 2E20A-G). These trenches would, ideally, encompass the entire area covered by these structures. However, the trenches were soon enlarged when various parts of the excavated passageways and casemate revealed them to be much larger than originally anticipated.

Three-foot thick balks were left between the original trenches for stratigraphic purposes as well as for efficient removal of soil. Excavation of the trenches themselves was carried out in arbitrary layers except where significant stratigraphic layers warranted excavation by stratigraphy. In the latter case, the aim was to follow the layer to its limit.- although this was not always feasible.

Figure 2 shows the location of the original trenches with the structures in their theoretical positions, as well as the extended trench boundary. Figure 3 shows the structures which were actually uncovered and their locations within the revised trench layout.

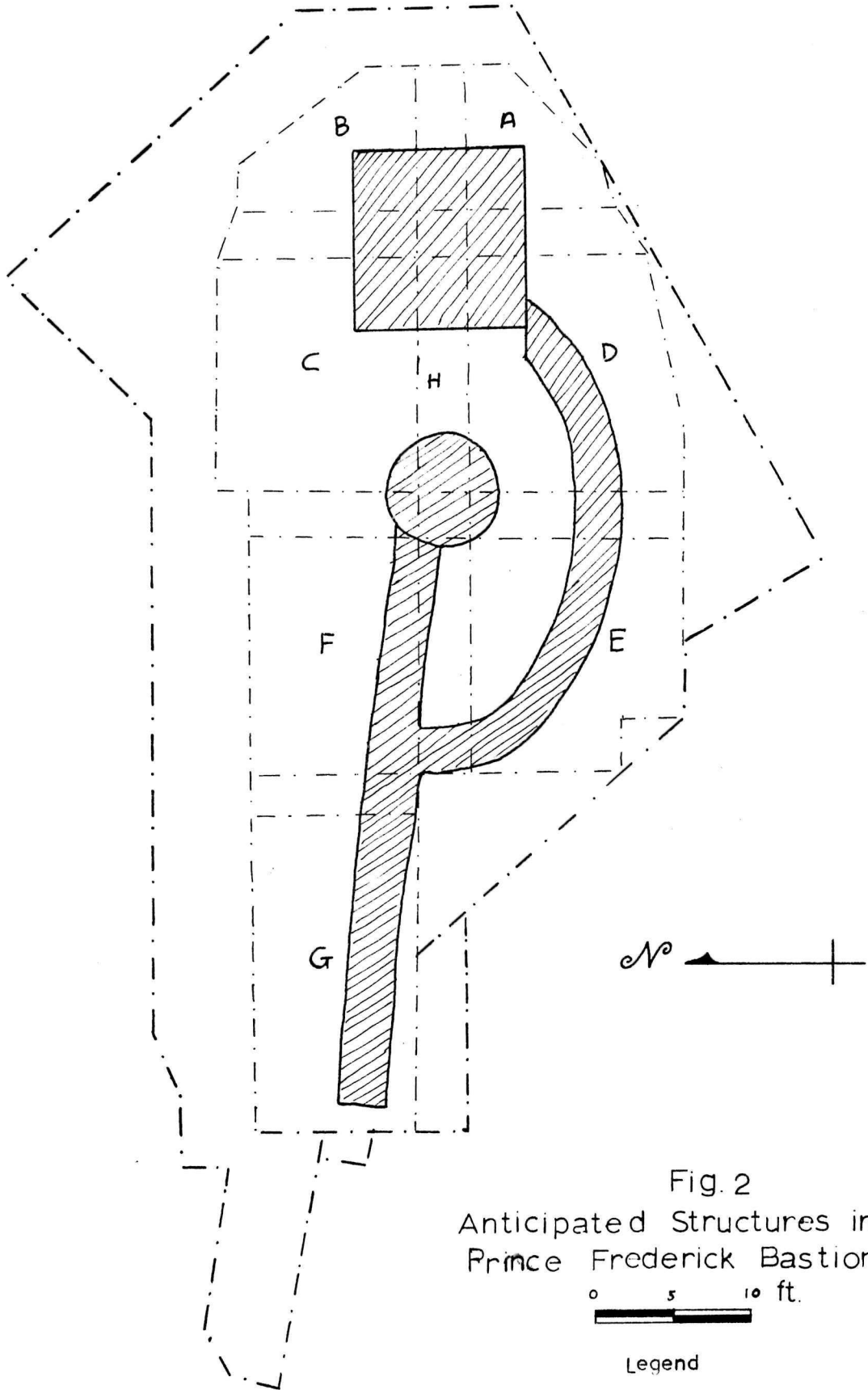
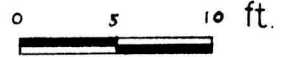

Fig. 2
Anticipated Structures in
Prince Frederick Bastion



Legend

The letters "A" through "H" indicate
the original trench limits.

Legend

Letters "A" through "H", plus "N" indicate trenches

J - Casemate

K - Well

L - Straight Passageway

M - L-shaped Passageway

P - Drain

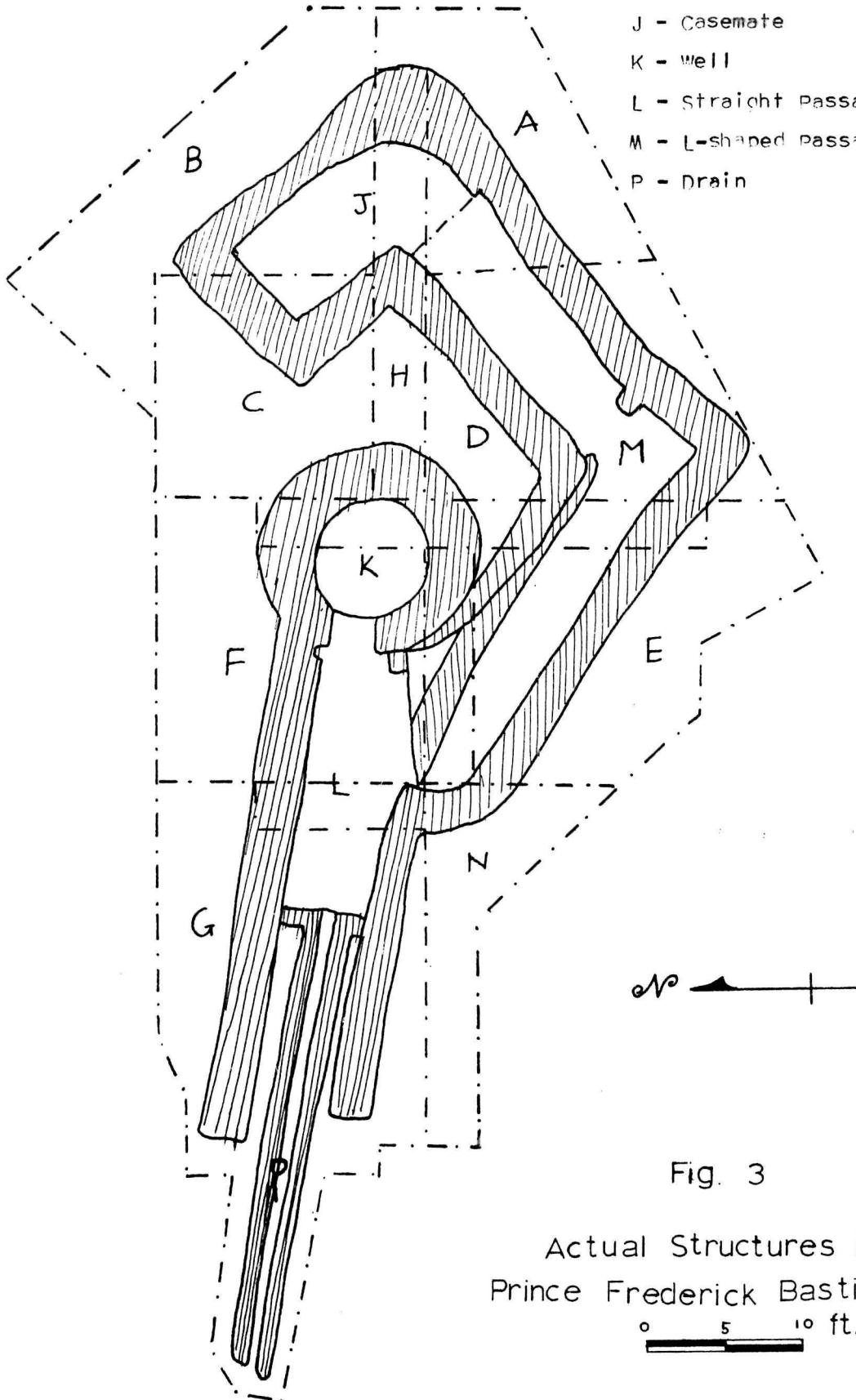

Fig. 3

Actual Structures in Prince Frederick Bastion

0 5 10 ft.

Description

By superimposing a plan of the structures found in this bastion on a surface contour map of the same area, two interesting patterns can be discerned. One is the location of most of the casemate and L-shaped passageway elevation of 135.0' A.S.L. (Fig. 4). The second is the location of a concave slope in the centre of the gorge, almost directly above the straight passageway.

When the stratigraphy of these two areas is examined, it is found that the casemate (2E20J), the L-shaped passageway (2E20M) and the sub-operations covering them (2E20 A,B,D + E) show a stratigraphy which indicates collapse (Fig. 5). However, the stratigraphy of the well (2E20K) the straight passageway (2E20L), plus the sub-operations over them (2E20F + G) indicate a building up of soil in horizontal layers (Fig. 6) as opposed to the vertical collapse pattern mentioned above.

The overall top soil of the bastion consisted of a layer of dark brown loam (10YR, 3/2), which had an average thickness of 0.5'. In some portions of the bastion - notably sub-ops. 2E20B,F and G, this soil had strong traces of dark reddish brown loam (5YR, 3/4) in it - a soil color which was dominant throughout most of the bastion.

Below the top soil, a layer of dark reddish brown sandy loam (5YR, 3/4) and reddish brown sandy loam (5YR, 4/3) covered that portion of the bastion included in sub-ops. 2E20A-E. A varying concentration was found in this 2.0' to 4.0' thick layer, with the heavier concentration occurring in sub-ops. 2E20D + E. These small rocks (pebble size generally) occurred to a lesser degree in

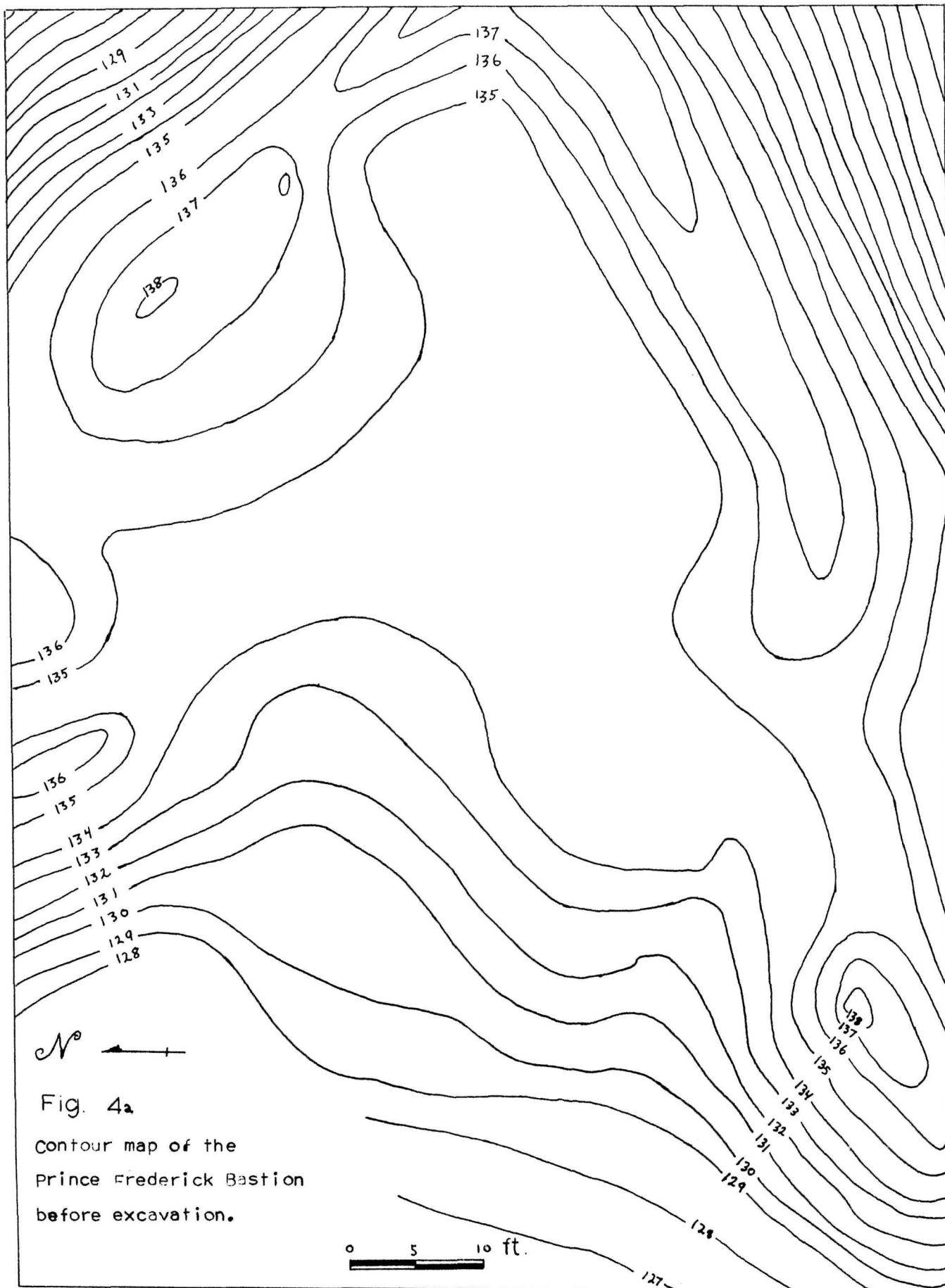

Fig. 4a
Contour map of the
Prince Frederick Bastion
before excavation.

0 5 10 ft.

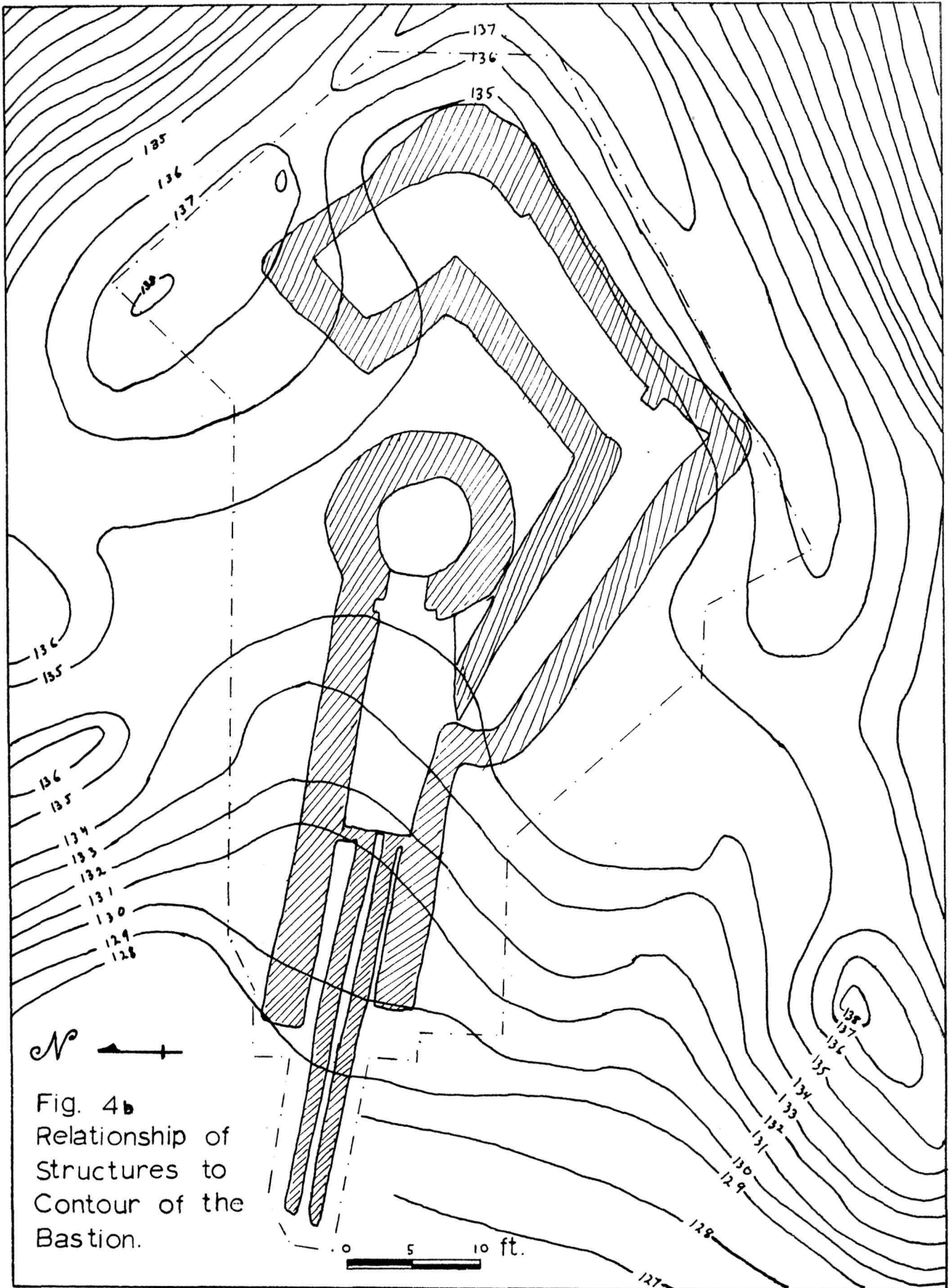

Fig. 4b
Relationship of
Structures to
Contour of the
Bastion.

FIGURE 5

This drawing shows a section view through the Prince Frederick Bastion from north to south. This drawing extends over the casemate and L-shaped passageway. The wood at the bottom of the trench is a part of the casemate roof. The stratigraphy is as follows:

- 1) Reddish brown loam (5YR 4/4).
- 2) Dark reddish brown sandy loam (5YR. 3/4), plus reddish brown sandy loam (5YR. 4/3)
- 3) Yellowish red loamy sand (5YR. 4/6).
- 5) Dark Brown loam (7.5YR. 4/4).

Note: Soil layer No. 3 was not found in 2E20B, hence the end of this layer is arbitrary.

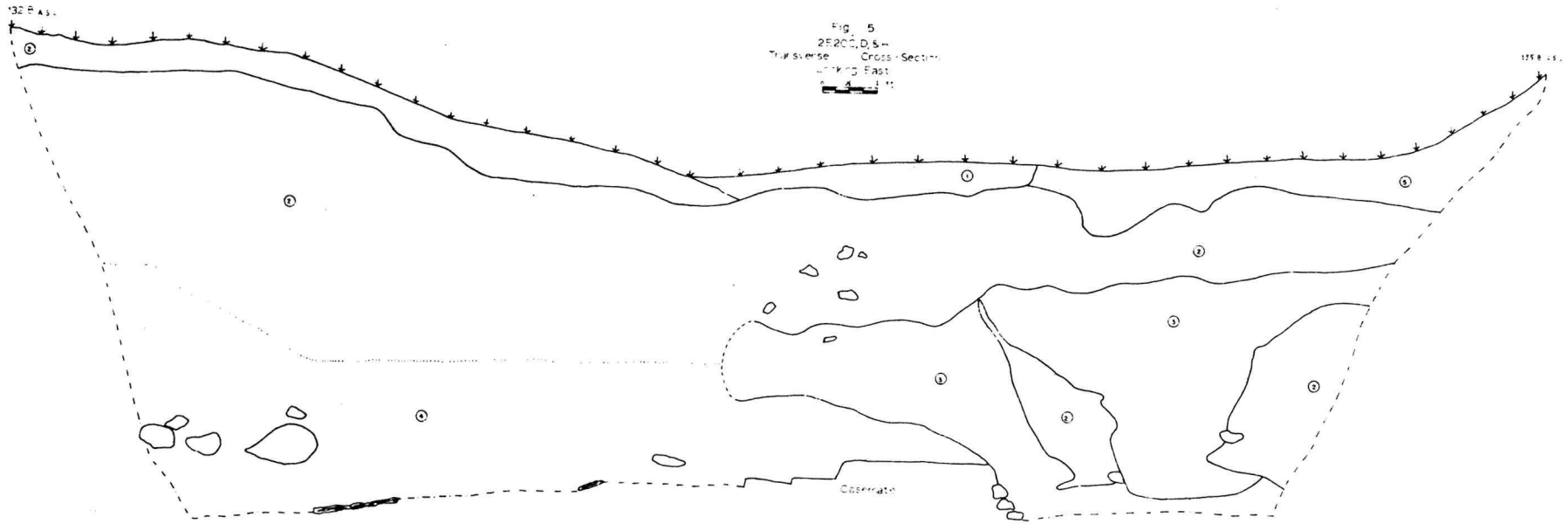

2E-67-102-17

Figure 6

This drawing shows the stratigraphy which covers the straight passageway and its north wall - along the west face of 2E20F. The stratigraphy is as follows:

- 1) Dark brown loam (7.5YR, 3/2).
- 2) Dark brown sandy loam (7.5YR, 3/2) plus field stones.
- 2A) Reddish brown sandy loam (5YR, 3/4).
- 2B) Dark reddish brown sandy loam (5YR, 3/4).
- 3) Dark brown loam (7.5YR, 3/2) with coarse mortar detritus, rubble, shells, brick & charcoal pieces.
- 4) Dark reddish brown loam (5YR, 2/2) - Trash layer, organic soil plus charcoal pieces.
- 5) Dark reddish brown sandy loam (5YR, 3/4) plus rubble
- 6) Dark reddish brown loamy clay (5YR, 3/4).
- 7) Dark reddish brown sandy clay (5YR, 3/4).

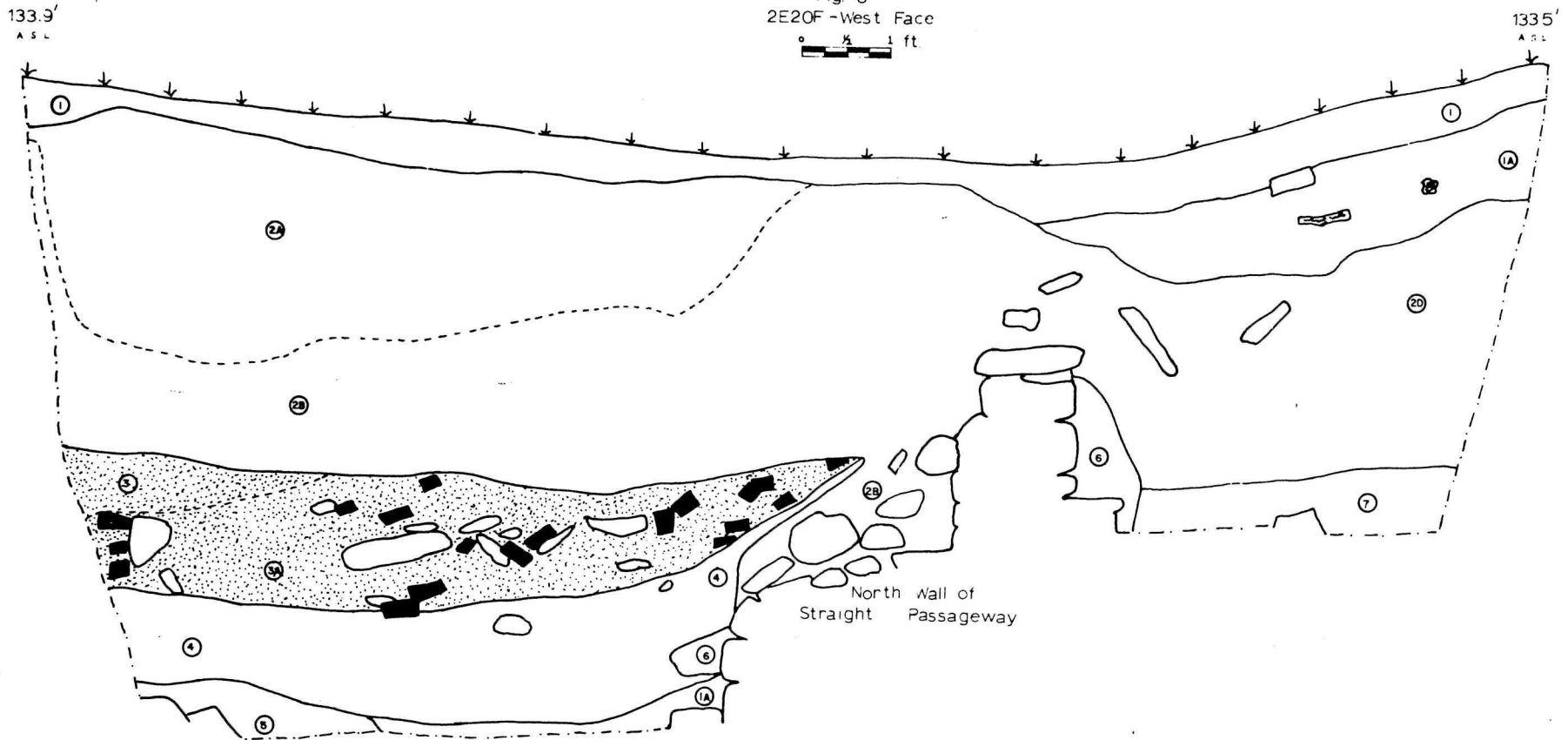

in sub-op. 2E20C and were virtually non-existent in sub-ops. 2E20A + B.

Immediately below this layer, the soil changed to a sandy clay, maintaining its dark reddish brown color. This layer existed in sub-ops 2E20A,B,C + B directly below the sandy loam layer; in 2E20F below the top soil; and in 2E20G below a 2.5' thick layer of dark brown sandy clay (7.5YR, 3/2). In sub-op. 2E20D the soil consists of a mixture of the above two soils plus yellowish red loamy sand (5YR, 4/6). These dark reddish brown sandy clay layers continue down to the top of the stone structures, which were located at from 128.0' A.S.L. (for the casemate) to 127.5' A.S.L. (for the L-shaped passageway) to 129.0' A.S.L. (for the straight passageway), and 130.5' A.S.L. (for the well); thus forming a layer of soil from 1.5' to 3.0' thick in sub-ops. 2E20A - E, and from 2.0' to 2.5' thick in sub-ops. 2E20F + G. These sandy clay layers consist of fill deposited in the collapsed depressions of the bastion.

Covering parts of the casemate and L-shaped passageway was a layer of dark grey marsh mud (5Y, 4/1). A similar mud layer was found on top of the wooden roofs of the casemates in operations 2E11, 13 and 18, and served as a protection against water penetration. Hence the discovery of wood planks or wood fragments - immediately below this layer was not unexpected. The soil below this level is located within the casemate (2E20J) and L-shaped passageway (2E20M) and is discussed in the report by Miss Winnie Frohn.

In the remaining portion of the bastion - the well and straight passageway - the stone walls were not covered by a layer of wood or marsh mud. A layer of mortar debris plus brick fragments was found below the dark reddish brown sandy clay layer over the well (2E20K), the straight passageway (2E20L) and the entrance to the L-shaped passageway (2E20M). This layer extended over these three structures, covering the broken interior walls of the straight passageway and well. The bottom of this layer

was concave in formation, following the interior of the straight passageway and well, as well as the entrance to the L-shaped passageway. This layer began near the west end of the passageway (2E20L) and gradually increased in thickness as it went east - becoming approximately 2.5' deep at the well entrance, and continued down into the well for an additional 2.5'.

The soil which was mixed in with this debris consisted primarily of dark brown sandy loam (7.5YR, 3/2) near the top of this layer, and dark reddish brown sandy loam (5YR, 3/4) at the base.

Below the layer of mortar debris, several layers of dark brown loam existed. One, a layer of dark reddish brown loam (5YR, 3/4) was found covering most of the north wall of the passageway (2E20L) and the entrance to the L-shaped passageway (2E20M) - in the area where these existed below sub-op. 2E20F. Below this layer, which was only from 0.2' to 0.4' thick, a deposit of very dark brown loam (10YR, 2/2) plus charcoal pieces was found. This layer covered the remaining portion of the damaged interior north wall and part of the interior of the passageway (2E20L). Like the previously mentioned layer, it was only 0.2' to 0.4' thick and located mainly within the limits of sub-op. 2E20F and the balk west of it (2E20H). The layer went down to an elevation of 126.4' A.S.L. - or 1.4' above the average level of the straight passageway.

In the western portion of this passageway, the area covered by sub-op. 2E20G, the soil below the above-mentioned mortar debris consisted mainly of very dark brown sandy loam (10YR, 3/2) plus charcoal pieces. This layer was a continuation of a similar layer found in sub-op. 2E20F. However, it lies more over the centre of the passageway at this point than over the walls - as was the case in sub-op. 2E20F. In this sub-op. a layer of dark brown sandy clay (7.5YR, 3/2) covers the walls of the

straight passageway. This layer is located directly below the previous layer of very dark brown sandy loam, and merges with a layer of dark brown sandy loam, in the middle of the passageway. These two layers, like the loam layers in sub-op. 2E20F, end at 126.4' A.S.L. - at which level a layer of dark reddish brown sandy clay (5YR, 3/4) and dark brown sandy loam (7. 5YR, 4/2) is found throughout the straight passageway. This layer is only 0.4' thick and covers a 0.5' thick layer of reddish brown clay (5YR, 4/4) dark reddish grey clay (5YR, 4/2) and dark yellowish brown clay (10YR, 3/4).

The bottom layer of the passageway consists of a mixture of reddish brown clay (5YR, 4/4), dark reddish grey clay (5YR, 4/2), and dark yellowish brown clay (10YR, 3/4). This layer of soil, covered the cobblestone floor of the passageway as well as the stone drain found therein. The soil in the drain itself consisted of dark brown clay (7. 5YR, 4/2), whereas the soil on both sides of it consisted of a mixture of reddish brown sandy clay (5YR, 4/6) and yellowish red sandy clay (YR, 4/8).

Stratigraphic Pattern

From this stratigraphic record, the pattern of collapse and fill in the two passageways appears to be quite different. In the L-shaped passageway (2E20M), the soil type and layer formation suggest a natural collapse of the wooden roof and a subsequent filling in by the soil above, with one or two additional layers of loam added to the entire bastion at a later date. (For greater detail on this area see Frohn 1967).

In the straight passageway, however, collapse was relatively limited and probably occurred as a result of the removal of some of the stones from the interior walls. This action may have started as early as 1852 - 1854, when stones were removed from the fort to serve as boundary markers (Nadon 1966: D: 1). Present evidence indicates that the north wall must have been

at least three to four courses higher than the existing interior level (127.5' A.S.L.) - since the level of the exterior face is that much higher (129.4' A.S.L.) Once these inner stones were removed, the rubble core and less stable exterior face were probably pushed into the passageway by soil pressure. The discovery of a fairly large number of stones in the passageway adds support to this theory.

Similar action most likely occurred along the south passageway wall and the pressure in this case was possibly much greater than that against the north wall, since the remaining five courses of stone were pushed north into the passageway. These courses overhung to such an extent that when they were excavated, two of the courses either fell or had to be removed.

With the passage walls in such a state of collapse, the entrance to the straight passageway was probably soon blocked off, leaving the main area within the passageway and well open for a dumping ground for various layers of soil (such as mortar debris, charcoal and loam, etc.). The fact that three different layers did all end near the entrance to the straight passageway - at a place where a large quantity of rocks were located - suggests that the stratigraphy of that area was formed in this manner. Figure 7 shows how these stones formed such a separation in the passageway, as well as some of the other stones which collapsed into the area east of it.

The development of the stratigraphy of the well (2E20K) most likely occurred in a much similar fashion - although it cannot be verified whether the interior face of the well wall was removed or just collapsed, since the well was not excavated to its base.



Fig. 7 - 2E20L: View of stones forming separation in straight passageway and part of collapsed wall behind it. Note also quoin stones at entrance to passageway. Facing E. 6' scale (2E-491-x).

Figure 8

This drawing shows an east-west section view of the Prince Frederick Bastion. It extends from the west end of the straight passageway.

(2E20L) to the salient angle. The stratigraphy is as follows:

- 1) Dark brown loam (7.5YR, 3/2)
- 1A) Concentration of rubble and mortar
- 2) Dark reddish brown sandy loam plus field stones (5YR, 3/4).
- 3) Dark brown sandy loam plus charcoal pieces (7.5YR, 3/2).
- 4) Dark reddish brown sandy clay (5YR, 3/4) plus field stones.
- 5) Dark brown silty loam (2.5YR, 4/4).
- 6) Dark brown sandy clay (7.5YR, 3/2) plus rubble
- 7) Dark reddish brown loam (5YR, 3/4).
- 8) Dark brown sandy clay (2.5YR, 3/2) plus field stones
- 9) Dark reddish brown sandy clay (5YR, 3/4) plus field stones.
- 10) Dark brown sandy clay (7.5YR, 4/4).
- 11A) Dark brown loam (7.5YR, 3/2) plus coarse mortar detritus, rubble, brick and charcoal pieces.
- 11B) Finer mortar detritus than 11A.
- 12) Dark reddish brown loam (5YR, 2/2), plus charcoal pieces and shells.
- 13) Dark brown loam (7.5YR, 3/4) possibly decomposed turf.
- 14) Dark brown loam (7.5YR, 4/4).
- 15) Dark reddish brown sandy loam (5YR, 3/4) plus reddish brown sandy loam (5YR, 4/3).
- 16) Dark brown loam (7.5YR, 4/2).
- 17) Yellowish red loamy sand (5YR, 4/6).
- 18) Black Loam (5YR, 2/1).
- 19) Dark reddish brown sandy clay (5YR, 3/4).
- 20) Dark brown loam (7.5YR, 4/2), black loam (5YR, 2/1), reddish brown sandy clay (5YR, 4/3), Dark grey clay (10YR, 4/1).
- 21) Reddish brown loamy sand (5YR, 4/3).

Note: Depression in the top soil by the salient angle was caused by a cement gun platform.

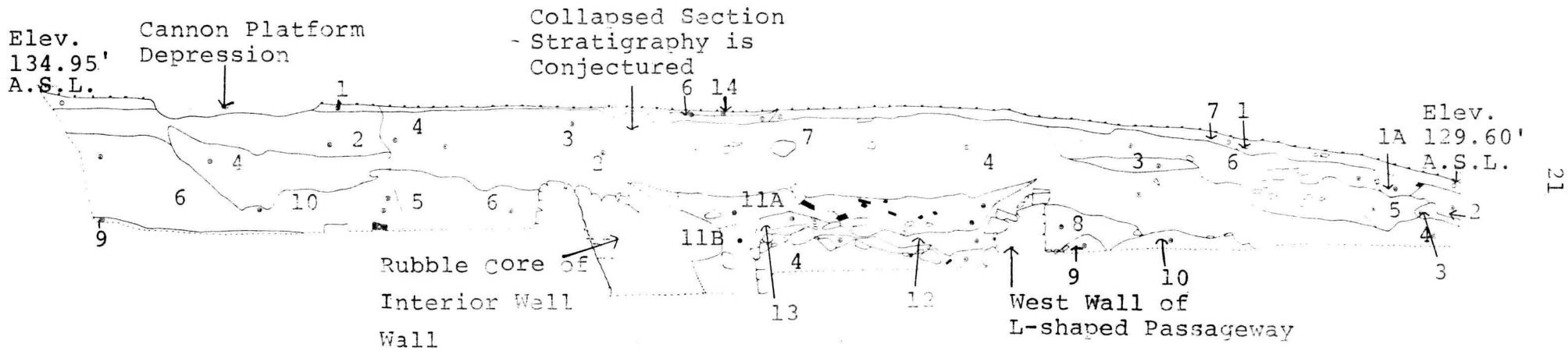

Fig. 8

2E-67-102-18

Since the stratigraphy of the well corresponds to that of the straight passageway (in that the mortar debris layer and charcoal layer both continue down into it) (Fig. 8), - it is possible that this structure collapsed at about the same time as the passageway. The actual filling of the well may have taken longer than the rest of the area, possibly since the water in the well would not allow the rubbish and soil deposited therein to form any kind of solid base. Hence as the water was displaced, the soil would sag and more of the well would have to be refilled to a certain degree. Such a process would not occur in the passageway, where the cobblestones provided a secure base.

This action might account for the rather large depression shown in Fig. 9 - directly over the well. Since the soil in this depression consists mainly of loam, it would appear that the rocks and loam were thrown there in an attempt to cover up any trace of the well.

However, the possibility also exists that this depression is the result of someone's attempt to relocate the well after it had been partly buried. Such action may have occurred while the fort was under lease to various people after 1833 (Nadon 1966: D: 1). However, this is unlikely, as a report on the fort in 1900 mentions that "the casemates were crumbling and gradually falling in" (Nadon 1966: D: 1); thereby suggesting that these structures were still visible to some extent at that time.

Figure 9

This drawing shows the stratigraphy over the well and is of the east face of sub-operation 2E20F. The stratigraphy is as follows:

- 1) Dark reddish brown loam (5YR, 3/4).
- 2) Dark reddish brown sandy loam (5YR, 3/4) plus field stones.
- 3) Dark brown loam (7.5YR, 3/2).
- 4A) Dark brown loam (7.5YR, 3/2).
- 4B) Reddish brown loam (5YR, 4/4).
- 4C) Dark brown loam (7.5YR, 3/4) - decomposed turf.
- 4D) Dark reddish brown loam (5YR, 3/4).
- 4E) Yellowish red loam (5YR, 4/6).
- 4F) Dark reddish brown loam (5YR, 3/3).
- 5) Dark brown loam (7.5YR, 3/2), plus mortar detritus and shell and brick fragments.
- 5A) Finer and creamier mortar detritus than 5.

134.5' A.S.L.

134.2'
A.S.L.

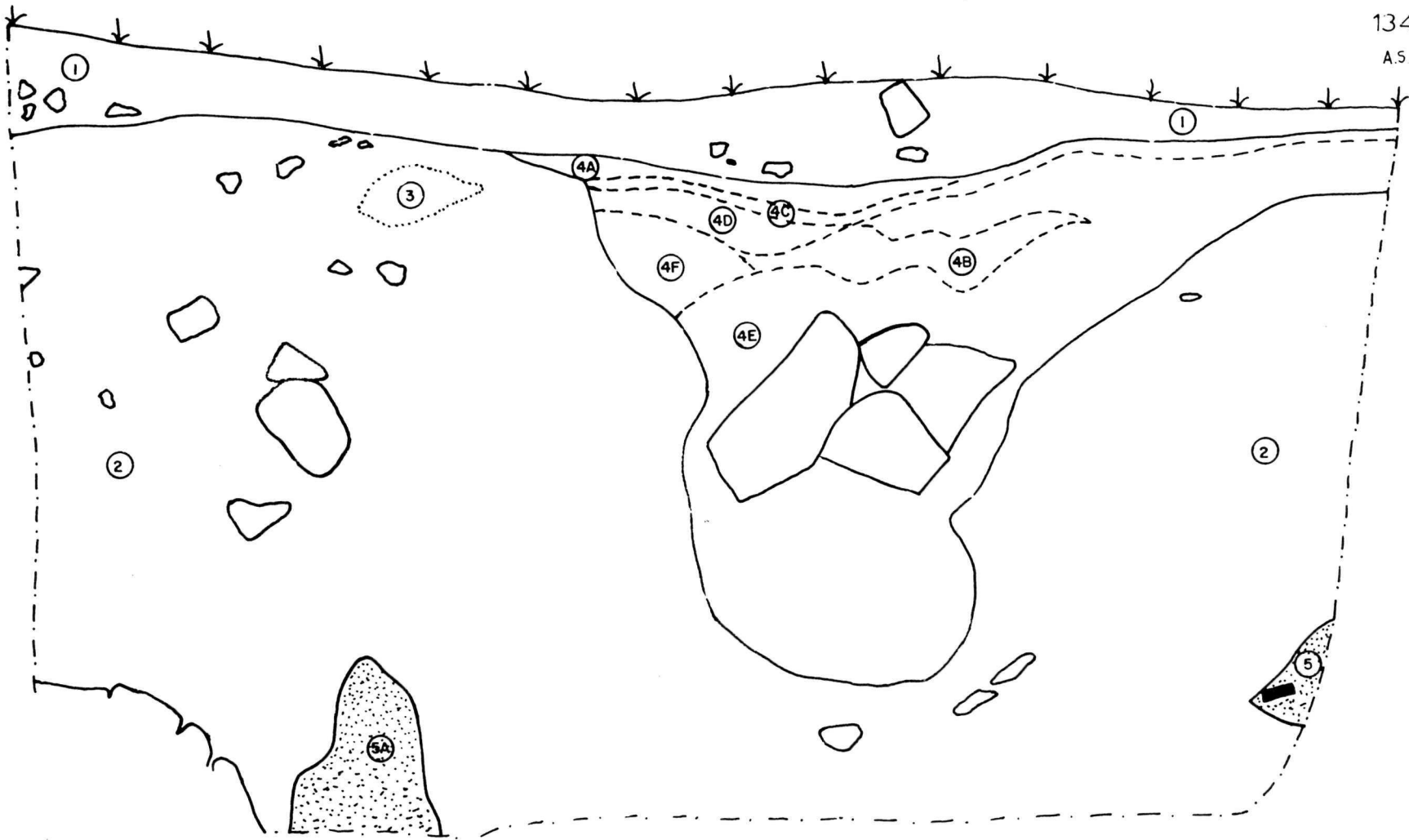

25

Fig. 9
2E20F-East Face



2E-67-102-16

CHAPTER III PRINCE FREDERICK BASTION - STRUCTURES

The Well

Sub-operation 2E20K consisted of a well located in the centre of this bastion. Referenced in both the French and English maps, the well would appear to date from 1751 at least, when the fort was a palisaded structure (Plan de Fort Beausejour, Franquet, 1751). Whether the excavated well is the French one, or whether it is a remodeled British version is not yet sure - partly because it was not entirely excavated. This aspect will be considered after the structural dimensions of the well have been presented.

The well has an interior diameter of 7.4' and an exterior one of 14.0'. It is not entirely circular, but has somewhat straightened sides along the north and south interior faces. This may have been the original shape of the well or else could possibly have resulted from parts of the well wall being forced inward due to soil pressure. An opening in the well wall is located in the west side and goes down to 124.9' A.S.L. - or 0.2' below the cobblestone floor of the straight passageway (2E20L). The entrance is 4.35' wide and is curved on the east side (following the curvature of the interior face of the well) and straight on the west side (where the east end of the cobblestone floor is located). Hence the thickness of the well entrance floor has a maximum width of 2.0' at the north and south ends, and a 2.2' minimum width in the centre. This compares with an average thickness of 3.3' for the well wall.

On each side of the entrance there is a small recess - approximately 0.65' wide and set back 0.65' into the well wall. Located on the exterior portion of the wall, they would appear to have been constructed at the same time as the entrance to the well - as they appear to form part of a recon-

structed section of the well. This section appears to have been rebuilt because there is a rather wide gap between the regular stone courses forming the interior wall of the well and the entrance stones (Figs. 10 and 11). This gap, which varies in width from 0.4' to 0.6', is quite substantial and would most likely have been filled in if the entrance was constructed at the same time as the well was. However, if the entrance was constructed later, then some of the stone forming this circular wall would have had to have been removed and a corner of some sort constructed. This is what has apparently been done, but these corners were poorly constructed. In addition, the stones of the entrance appear to be more closely related to the stones of the straight passageway rather than to those of the well's interior face - the basic difference in this case being the quality of workmanship on the stones. The stones of the passageway have sharper edges on them, while the stones of the well have been rounded off (Fig. 12). This difference adds to the theory that the well entrance is, in fact, a later modification.

Another feature noticed in the well entrance was the presence of wood. At least two layers of decayed wood cover the stones of the entrance. The grain of this wood has a north-south orientation, and the presence of two differently colored wood sections suggests that two planks formed a wooden floor at this place, rather than a single wide board. A few nails were found in this area, as well as slight traces of wood with an east-west orientation along the south wall of the entrance floor. This suggests that either small sleeper beams or else possibly a third layer of wood may have been located here at one time.



Fig. 10 - 2E20K: View of north side of well entrance showing break in the construction plus stone slot. 6" scale, Facing North. (2E-136-M)



Fig. 11 - 2E20K: View of south side of well entrance showing break in the construction plus stone slot. 6" scale, Facing Southwest. (2E-137-M)

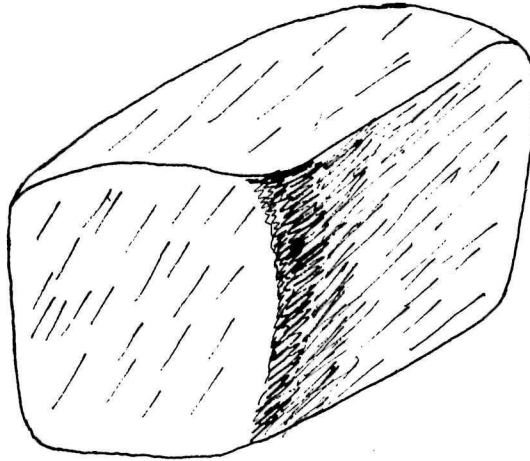

Rounded Stone of the Well (2E20K)

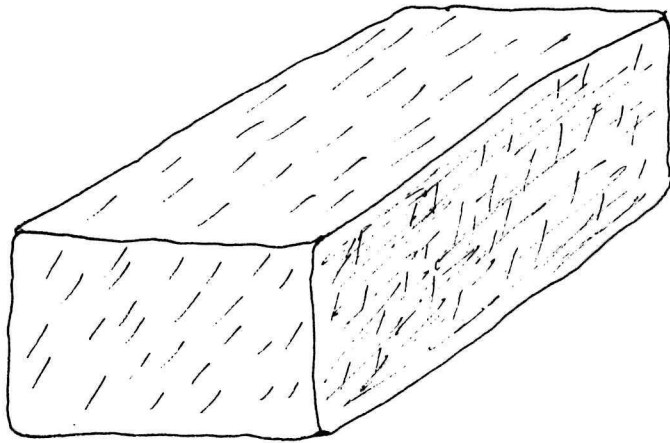

Squared Stone of the Straight
Passageway (2E20L)

Fig.12 Rounded and Squared
Stones - no scale

The construction of the exterior face of the well wall is quite different from that of the interior face - consisting basically of field stones, as opposed to worked stones for the interior face. The fact that most of the exterior face was found at an elevation of 130.5' A.S.L. suggests that possibly this wall is still at its original height. Moreover, a small fragment of wood was found on top of the exterior face - which slightly increases the possibility for a wooden covering existing on the well at some time. (This theory will be further discussed in the section dealing with a possible restoration of the well.) Although no other wood was found on the wall itself, a wooden post was beginning to be uncovered inside the well at the time when excavation ceased. This post was 0.15' wide, 0.2' thick, and 2.5' long (at least). It slanted down from 125.4' A.S.L. at the entrance of the well to 122.25' A.S.L. in the centre.

The exterior face of the well is composed of field stones varying in size from 0.3' by 0.2' by 0.2' to 1.0' by 0.8' by 0.9'. Because of this large difference in sizes, the courses forming this part of the wall are very difficult to determine and are almost non-existent. In contrast to this, the interior face consists of a yet undetermined number of well defined stone courses (9 of which were excavated to date). Between these two faces there is a rubble core of small stones. None of the stones forming the well wall appear to have been joined with mortar. However, the presence of mortar traces inside the well may have resulted from mortar leaching out into the well or perhaps (and more probably) have filtered down from the mortar layer above it.

The actual structure of the interior face of the well wall causes some questioning as to its period of construction. The well would appear to date from the French period, as it would probably be easier for the British to dig a new well elsewhere than to completely reconstruct an old one. Nevertheless, some alterations appear to have been made near the top of the existing stone courses of the interior face (i.e. at the level of the entrance of the well). Since this break in the wall was probably made when the palisaded bastion was filled with soil, it is also possible that the entrance was first made by the French - presuming the height of the well was the same as it is now. This entrance may later have been reconstructed by passageways. However, several other reasons also suggest that the well is mainly of French construction.

One is the termination of the north wall of the straight passageway at the entrance to the well. If both structures had been constructed concurrently, most probably the stones at the entrance to the well would have been bonded, whereas in actual fact they abutt (Fig. 13).

The second reason is one already mentioned earlier (See p. 12) - the structure of the entrance to the well, which appears to form a deliberate break with the interior face of the wall. The stones forming the north and south sides of the entrance not only differ in size from those of the interior face of the well (being somewhat larger on the whole), but they are also worked to a greater extent. The edges of these stones are sharper like those of the stones in the straight passageway - whereas the stones of the well are slightly rounded (Fig. 11).

Fig. 13 - 2E20L: View of abutted joint between the north passageway wall and the well entrance. Facing North. 3' scale. (2E-586-X)



Fig. 14 - 2E20L: View of passageway entrance showing stones jutting out by the interior face of the north wall. 6' scale. Facing East. (2E-718-X)



In a similar fashion the top two courses of the interior face of the well wall appear to have more of the sharp edge characteristics than the round edge ones, and hence might suggest a possible reconstruction of the entire top of the well after the British takeover in 1755.

The Straight Passageway

The straight passageway is located in the gorge of the bastion and lies in an east-west direction. It is believed to be a British structure, since its first appearance occurs on a British plan of the fort dated between 1755 and 1778, although there is some doubt whether or not the actual structures shown on that map are in fact the actual ones excavated. The passageway, for instance, is almost three times as wide as the map shows it to be, and the well twice as wide. Further, the curved passageway shown on that map is, in reality, l-shaped and meets an almost rectangular casemate, as opposed to a square one as shown on the plan. Also, the position of the actual casemate is at a 45 degree angle to the one on the British map (Figs. 2 and 3).

The straight passageway extends west from the entrance to the well for a distance of 31.7', not including the drain. With the drain, this length is produced to 45.8'. The mean interior width of the passageway is 4.5' and its walls vary in thickness from 2.9' to 3.4' for the north wall, and from 2.4' to 2.9' for the south wall. There are four distinct features in this passageway: the north wall, the south wall, the cobblestone floor, and the drain.

The North Wall

The interior face of the north wall consists of from 3 to 6 course of shaped stones, ranging in size from 0.45' by 0.9' to 0.8' by 2.0'. A small number of field stones also found in this wall range from 0.3' by 0.7' to 0.7' by 1.4'. For the most part, this wall is vertical with no overhang. However, from the west end of the cobblestone floor to the west end of the north wall, a number of stones jut out into the passageway. These stones are located at from 124.5' A.S.L. to 125.75' A.S.L. A few of these stones by the west end of the wall are shaped, the others are field stone (Fig. 13).

Although only a small portion of the exterior face of the north wall was exposed, it would appear to consist mainly of field stones, arranged in a similar pattern to the stones forming the exterior face of the well wall - namely, virtually no use of stone courses. There may be some connection between the two walls because of this, however, it is more likely that this was standard construction for both the French and the British - to use field stones for a wall which was not exposed to view of weathering. A slight overhang of 0.2' occurs along the west end of this wall.

The highest stone of the exterior face of the north wall (located 9.1' west of the well entrance) is found at 131.0' A.S.L. - or 6.0' above the cobblestone floor. Hence, it is probable that the interior face also went to this height at one time, and possibly even higher, since the exact original height of this wall is not known. Like the well, this wall had shaped or worked stones forming the interior face, and field stones forming the exterior face and rubble core. Five quoins are located near the west end of the

passageway at a distance of 29.6' west of the well entrance (Figs. 7 and 14). These five stones are cut, and are sloped on the west face. However, the stones are much deteriorated and have obviously moved from their original positions, since some overhang others. Nevertheless, an estimate of their complete original slope can be made, and is placed at from 45 to 55 degrees. This slope most probably followed the slope of the gorge of the bastion at this point.

The quoin stones themselves are only roughly cut and have been slightly rounded at the edges in places, probably due to weathering. These stones vary in size from 1.2' by 0.5' by 1.0' to 0.8' by 0.4' by 1.1'.

The bottom portion of the north wall (located at 126.0' A.S.L.) continues west of the quoin stones for an additional 2.8'. The reason for this is not known - perhaps it has something to do with the Men's Barracks, which is located only a few feet west of this passageway. Such a feature does not occur at the west end of the south wall of the straight passageway, however.

The South Wall

The south wall also differs in several aspects, but its length (including the entrance to the L-shaped passageway) is 29.6' - the same as the north wall from the quoin stones to the well entrance. The wall itself is 22.3' long, with a 7.3' long opening between the well and the east end of this wall, thus giving it a total length of 29.6'.

Eight quoin stones are located at the west end of this 2.8' thick wall, however, only one of these stones remains well cut - the others having

probably been corroded by weathering. Most of the stone courses forming this wall are tilting in toward the passageway, probably due to soil pressure south of the wall. The interior face overhangs by 0.5' and some of the stones which had a greater overhang either collapsed or were removed during excavation.

There are still from two to four courses in existence, but a fifth was originally uncovered. This latter course collapsed during excavation due to overhang. The maximum height of this wall - as excavated - was 4.6' above the cobblestone floor (or 129.6' A.S.L.) - but it was obviously higher originally, as it would have to retain the soil of the bastion and, perhaps, a ramp leading up to the gun platforms.

The soil structure inside the passageway suggests that the south wall collapsed northward - probably after some of the stones had been removed, since not enough stones were found to reconstruct even a low wall. Also, several of the quoin stones were missing, again suggesting that stones were removed from this passageway.

The exterior face of the south wall appears to have been constructed in a somewhat better fashion than the exterior face of the north wall, as it is composed of definite courses of worked stone - not just vague courses of field stone. This may have some connection with a ramp or staircase up to the gun platforms, which must have existed close to one of the sides of the straight passageway - if not along the curtain wall. If such was the case, this portion of the passageway may have been exposed to view and weathering, and hence would be better constructed than the exterior faces of the north wall and well.

Both the interior and exterior faces of this wall slant toward the interior of the passageway, thus offering additional evidence that soil pressure caused part of the wall to collapse. A rubble core also exists in this wall, however, the large number of worked stones in this wall lessens the width of the core to 0.4', as compared to 0.9' for the north wall.

The east end of the south wall joins with the north end of the L-shaped passageway. Unlike the break between the north wall and the well, the stones of the south wall and the L-shaped passageway bond. Nevertheless, the construction of this corner is not stable, as it is comprised largely of a worked stone interior face and a field stone exterior face - with small field stones used as a rubble core. The lack of mortar, noticeable in all the structures of this bastion, greatly limits the stability of these structures; and, from the large amount of stones found at the entrance of the L-shaped passageway, it would appear that part of this wall collapsed in that area.

The Cobblestone Floor

On the floor of the passageway, two noticeable features occur: the cobblestone floor and the drain. The cobblestone floor is located between the drain and the well entrance, covering an area approximately 15' long by 45' wide. As Figures 15 and 16 show, this floor is not complete, but lacks stones along the entrance to the L-shaped passageway. The exact reason for this is uncertain. But excavation stopped at 124.55' A.S.L. or 0.2' below the top of the lowest portion of the cobblestone floor (next to the grate).

Fig. 15 - 2E20L: View of west half of the cobblestone floor with metal section by stone groove in bottom left corner. Facing West. 6' scale.(2E-71-B)

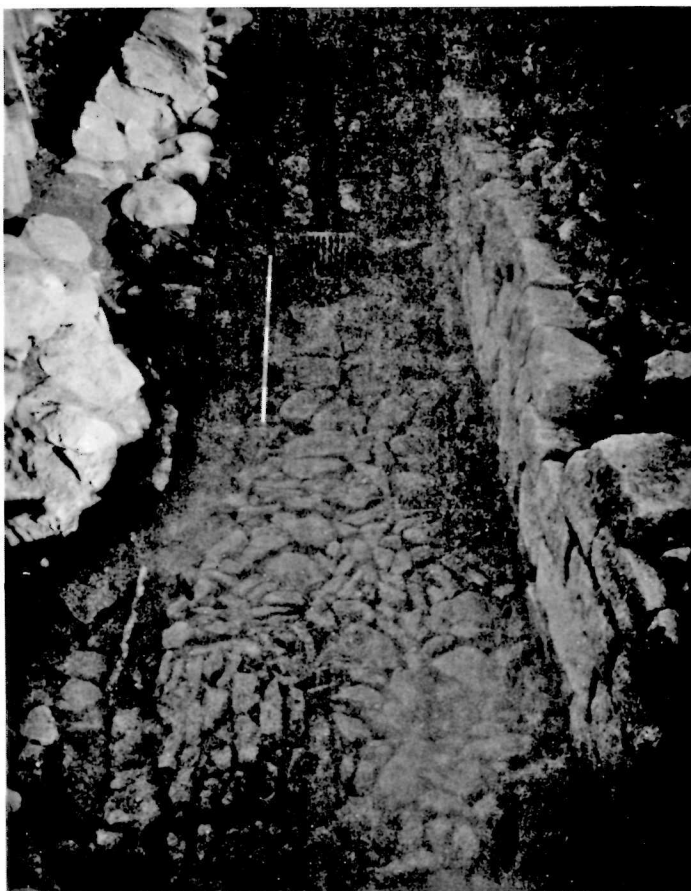

Fig. 16 - 2E20L: View of east half of the cobblestone floor with well entrance in the foreground. Facing West. 8' scale.(2E-72-B)



Hence some type of floor may still exist further down. Then too, it is possible that there is some relationship between the missing floor section and the stone drain which leads from the L-shaped passageway and goes directly below this floor, heading west towards the grate and drain in the straight passageway.

The size of the cobblestone does not appear to have been chosen for any particular pattern, nor are they very flat - as would be expected. This floor does, however, appear to have been constructed in two basic sections. The western part, consisting primarily of larger, flat stones, contains stones varying in size from 0.7' by 0.6' to 1.0' by 0.6'. The eastern portion - which lies almost directly in front of the L-shaped passageway - consists mainly of narrow long stones, many of which lay in an east-west direction. Average size of these stones is 0.9' by 0.3'. The photos of this floor in Figures 15 and 16 clearly show the distinction between the two sections.

At the east end of the passageway, the cobblestones end abruptly at the place where wood traces form the entrance to the well; whereas at the entrance to the L-shaped passageway they apparently merge with a series of small stones forming what appears to be a stone groove for a wood sill. When first excavated, this groove consisted of a cavity in the soil 0.4' deep and 0.4' wide, extending the entire length of the entrance (7.3'). Wood traces were present on both sides of this narrow trench and a layer of decayed wood covered the bottom of the groove. Along the north wall of this depression, a section of metal and wood was found intact - possibly part of a door. The discovery of a very large iron rust stain, a section of a door hinge, and

numerous pieces of rusted metal in the straight passageway opposite and west of the groove further suggest the presence of a collapsed, broken or dismantled door in this area. Several iron nails were found in the immediate vicinity and one was found in the groove itself. Possibly this conglomeration of iron fragments are the remnants of dismantling work carried out in the fort in 1833, when Fort Beausejour was abandoned as a military post (Nadon 1966: C:7).

The Drain

The fourth feature of the straight passageway was the drain. It extends west from the west end of the cobblestone floor for 20.7' and ends somewhat irregularly at 0.85' east of the Men's Barracks (2E16) south wall. The drain itself is composed of three rows of stones - one for the base of the drain and the other two for the drain walls (Fig. 17). The interior width of the drain varies from 0.54' to 1.65', with a mean width of 0.9'. Average stone size tended to range around 0.65' by 0.6' by 1.0'. The stones forming the walls of the drain were probably selected for their relatively straight sides, more likely due to fracture rather than being worked.

Although no worked or shaped stones appear to have been used for the base of the drain, it is quite flat. The stones in the centre of the drain base tend to be square in shape, whereas the stones at the ends tend to be more irregular in formation. The average size of the square stones was 0.7' by 0.7' as opposed to 0.6' by 0.6' for the irregular ones. There is a 0.44' slope in the drain, going from 125.63' A.S.L. at the east end by the grate to 124.19' A.S.L. at the west extremity by the Men's Barracks (2E16).

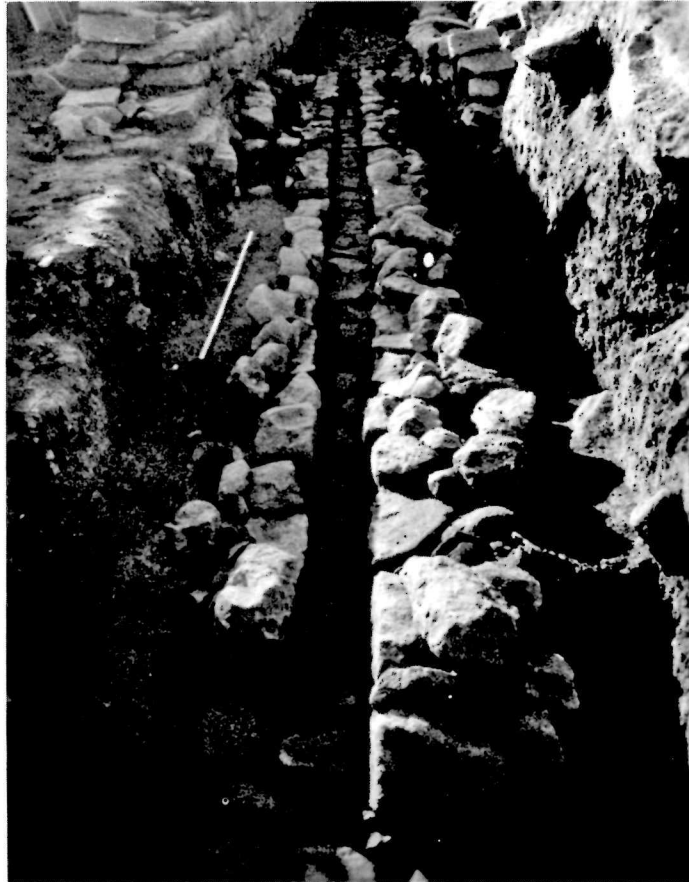

Fig. 17 - 2E20P: View of the drain, looking East. 6' scale. (2E-70-B)

The east end of the drain is blocked off by an iron grate. This grate has six vertical square bars (spaced 0.08' apart) welded to a single flat piece of metal. The entire grate protrudes 0.1' above the top of the drain, and the base - because it continued below the cobblestone floor - was not excavated. Two large stones, located at each side of the drain's east end, block off the cobblestone floor from the area beside the drain, thus forcing all water to leave the floor via the drain.

No wooden planks were found covering the passageway floor in the section where the drain is situated, however, traces of a single plank did exist directly over the drain. These wood traces were found 0.3' west of the grate and continued west for an additional 9.7'. Also, some wood - which may be part of a sleeper beam - was found 2.5' west of the grate at right angles to the above mentioned wood. The wood plank traces end at a place where several of the stratigraphic layers also terminated and where a number of stones were found forming a possible collapsed "arch" (Fig. 7).

Although it appears unlikely that an arch did exist in this area of the passageway - since there is no evidence of any roof covering the straight passageway - the presence of this feature should be examined. The "arch" was located 22.7' west of the entrance to the well and appeared to be 3.0' wide, thus extending west to a total of 25.7'. It consisted of approximately 15 stone slabs, most of which were in a vertical position (from which the theory of a collapsed arch originated). These stones varied in size, measuring from 2.1' by 1.0' by 0.3' to 1.4' by 1.2' by 0.5' to 1.0' by 0.8' by 0.2'. However, the lack of any traces of a roof over the straight passageway would question

the necessity of an arch between the north and south walls. Furthermore, none of the stones forming this "arch" were wedge shaped (a characteristic of stones in an arch).

This does not, however, rule out the problem of why nearly all of the stones were in a vertical position and in a straight north-south line. Nor does it explain why the wood over the drain or the stratigraphic layers mentioned previously end here. Probably this feature was in existence before the charcoal and mortar debris layers were deposited, and hence acted as a wall behind which the various layers accumulated. As for the wood traces over the drain ending in this bastion (which were actually 1.2' below the arch) it is possible that these did in fact continue further west but were removed during excavation.

The question now arises whether or not the drain and passageway are of the same period, or if one predates the other. Structurally the drain would appear to fit quite well with the rest of the straight passageway - that is, there does not appear to be any major discrepancy in the layout of the drain is 0.6' above the cobblestone floor, the base lines up very well with it, showing no sudden rise or drop where the two meet. As for actual architectural similarities, little can be said due to the entirely different type of structures involved. There are no bonded stones between the drain and the two passageway walls, nor do any corners exist in the drain which could be used as a comparison.

The Gun Platform or Traverse

In addition to the stone structures excavated in this portion of the bastion, one wood structure was also uncovered. This consisted of several

pieces of wood plus three iron spikes, located north of the entrance to the L-shaped passageway, above the north wall of the straight passageway's exterior face. This wood appears to follow the slope of the bastion, since it is located at 1.2' B.S., thus resting at 133.7' A.S.L. at the east end (near the well entrance) and at 132.3' A.S.L. at the west.

The wood was found in an area where a gun platform or traverse may have been situated, since it is just south of the embrasure in the left flank (Plan de Pte. de Beausejour, 1752 and Plan of Fort Beausejour No. H.M. 15414). Only a few traces of wood were found, but these were sufficient evidence to indicate the presence of some sort of structure (Fig. 18). The spikes, which lay at right angles to the wood, further add to this theory, as did a large number of knots. These imply the presence of other wood at right angles to that excavated. One piece of wood in particular appears to be either a cross beam or else the west end of this structure.

Unfortunately too little of the wood was actually uncovered to make an accurate reconstruction of this feature - or even to positively identify it. Possibly the information of this structure could be combined with that of a gun platform found in the Prince Henry Bastion and with traces found in the Prince Edward Bastion (See Field Drawings: 2E66-8-4 and 2E-66-33-2). However, even a combination of these three drawings still presents a very sketchy picture for any reconstruction attempt.

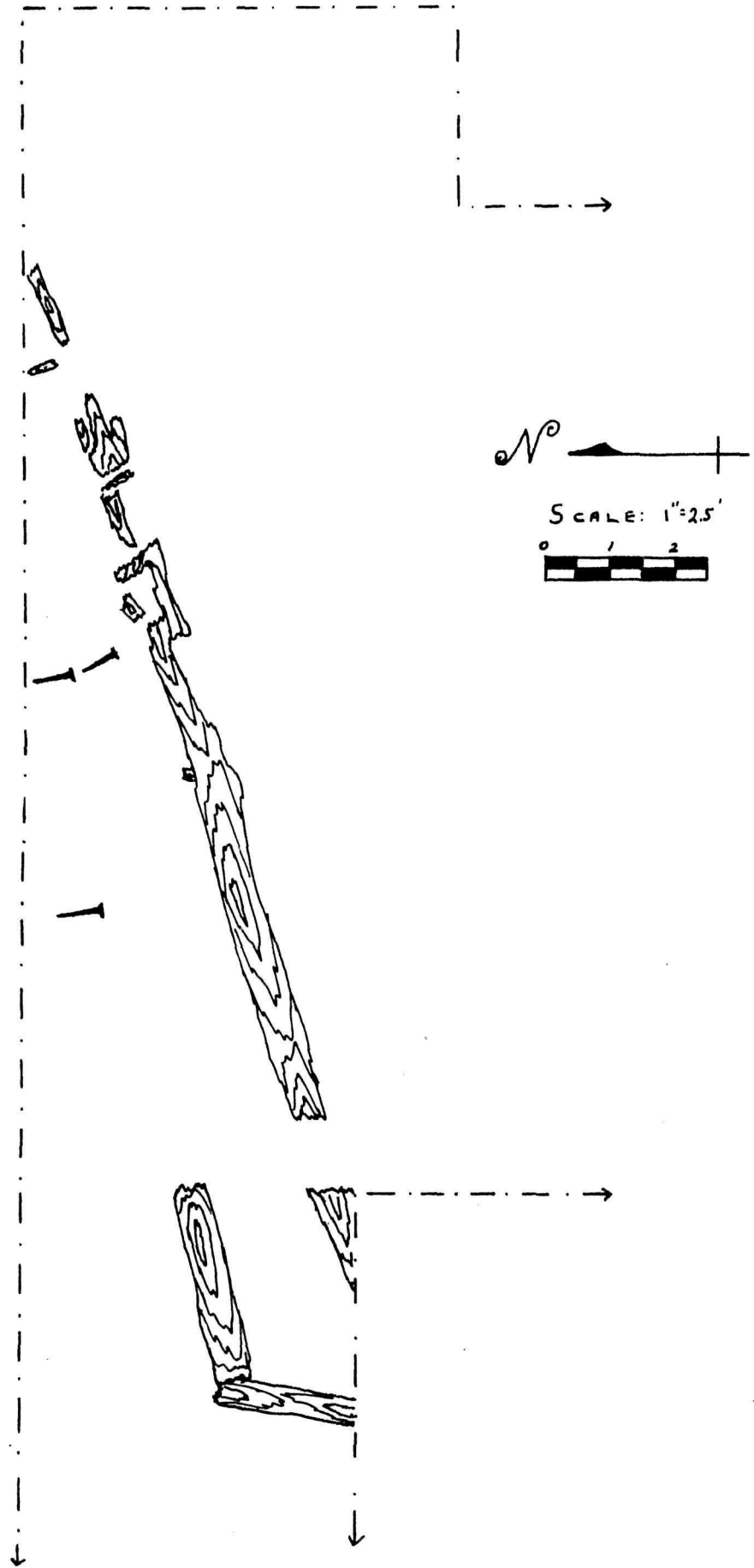

Fig.18

Gun Platform or Traverse

CHAPTER IV SUMMARY AND CONCLUSIONS

In short, the 1967 excavation in the Prince Frederick Bastion uncovered a stone casemate (the only stone casemate found in any of the bastions so far), as well as two stone passageways, a well, and two stone drains. In addition traces of a possible gun platform or traverse were also uncovered.

All of the stone structures uncovered lacked the presence of mortar and hence - being relatively complete - serve as good samples of French and British architecture in rural Maritime districts during the late 18th and possibly early 19th centuries.

However, this excavation also presents some problems - the largest of which is the difference between the plan of these structures and their actual locations. This may be due to mismeasurement, since several of the buildings in the Fort are found at slightly different places on two different plans. However, the buildings or structures indicated did correspond in outline, whereas the structures found in the Prince Frederick Bastions were almost completely different. Although the well was circular in all cases, it was almost twice as wide as the one shown on the 1755 to 1778 plan (Plan of Fort Beausejour No. H.M. 15414). Also, as was previously mentioned, the other structures also varied to a great extent. So much in fact, that perhaps the structures shown on the 1755-1778 plan were a different set and were replaced by the present ones at a later date. If such was the case, then perhaps some portion of the other structures (if stone constructed) could possibly have been integrated with the existing features; or if made of wood, may possibly still exist in part below the present levels of excavation. Such an

occurrence could possibly explain the presence of a wooden door between the south exterior well wall and the north exterior wall of the L-shaped passageway which was found there in 1962 (62-1-119, 137). This door was found at 11.0' B.S. (or 123.3' A.S.L.) - which puts it at 4.2' below the present limit of excavation.

Hence it might prove advantageous to excavate the areas outside of the present stone structures to determine whether or not other structures were located in this bastion. Similarly excavation might continue in the two passageways to determine if any structures lie beneath them. This latter action would probably also explain where the drain from the L-shaped passageway leads after it disappears below the cobblestone floor of the straight passageway. This objective may also be accomplished by excavating deeper directly north of the straight passageway and the drain therein, since this is the general area to which the second drain seems to be heading.

In regard to any restoration work in the bastion, much of the structures still remains, and so the work should consist of a straight reproduction in most cases. The original heights of both the casemate and L-shaped passageway exist, so the only research necessary here would pertain to the wood features inside and the roof. Several doors existed in this area - possibly as many as four. One was certainly located at the north entrance to the L-shaped passageway, and a second most probably at the place where the sloping walls of this passageway discontinue - since sills were encountered at both of these locations. Two other doors may also have existed, blocking off the two ends of the south arm of the L-shaped passageway. A wooden floor most likely covered the latter area, as depressions for sleeper beams were found. Again, research would be necessary to determine exactly how this wood was placed and how the doors were constructed and held in place.

As for the straight passageway, this does not appear to have had a wood and soil covering similar to that of the L-shaped passageway and casemate, as such a feature would probably have resulted in similar collapse patterns. However, such was probably not the case, since the stratigraphy of the straight passageway suggests a layer by layer horizontal filling. Hence, the passageway may have been open, or else covered with wood planks at the very top of the passageway walls, where they would come level with the gorge of the bastion.

Since an open passageway would be somewhat dangerous and inconvenient for the men working on the bastion, it is highly probable that wood covered this passageway at its original level - possibly 133.0' A.S.L. This level is deduced from the wooden gun platform (or traverse) traces found at 133.0' A.S.L., which was probably level with the gorge of the bastion originally. Hence, any passageway walls coming up to this level would have to be approximately 8.0' above the cobblestone floor of the straight passageway in order to fulfill these conditions. The wood, it should be noted, would not be covered with soil, and hence was probably removed in 1883 when the fort was dismantled, or after that date, when the remaining wood structures were gradually dismantled by the local inhabitants (Nadon 1966: C:7; D:1). This would be followed by the removal of some of the stones of the passageway walls and its eventual collapse.

As was mentioned earlier, the south face of the south wall of the straight passageway was constructed of worked stones rather than field stones. Hence, the possibility that a ramp leading up to the gun platforms existed south

of this wall may have resulted in a special construction of this part of the wall in a similar fashion to that of the interior face. Therefore, this area should be further excavated to determine if a ramp did exist here and part of the south passageway wall was exposed, or whether the south face of this wall was completely buried in soil.

The cobblestone floor is most likely still in its original state. However, if reconstruction does occur, more stones would probably have to be added in order to form a complete floor - unless further excavation in this area could prove that the existing pattern was deliberate and that the section without stones has a definite purpose - such as a drain.

In the other half of the straight passageway, where the drain is located, little work would be required. Two possibilities exist as to its original condition. One is that the drain alone was covered with a series of planks from the grate at the east end to the Men's Barracks at the west. The area on both sides of the drain would, in this case, be filled with sand or gravel - not soil - in order to provide a firm foundation to walk on. This set up would enable repairs and cleaning of the drain to be made without disrupting the entire passageway floor. Since wood was found covering the drain in this way, and since a sandy clay was present on both sides of the drain, this solution seems quite probable.

The alternative theory also requires that some substance be placed in the areas next to the drain, but would have short planks covering the entire width of the passageway from the west end of the passageway to the grate - being at right angles to the passageway walls. This poses several

problems however. One is the lack of any trace of wood in such a formation, and a second would be - what sort of covering is over the drain after it extends beyond the passageway? The only point in favour of this theory is that wood in this pattern would form a level ending by the grate, whereas a single plank would leave the centre portion of the passageway slightly higher. However, in my opinion, a reconstruction having a single plank over the drain would be the more correct structure.

When considering restoration of the well, it must be determined whether the well existed at much of its present level of 130.5' A.S.L. or whether it went to the same level as the theoretically reconstructed passageway level of 133.0' A.S.L.

Two facts suggest that the exterior face of the well wall is at its original level. One is that most of this portion of the well is located at an elevation of 130.5' A.S.L. ($\pm 0.3'$). The second is the fact that a single piece of wood (0.5' long by 0.2' wide by 0.05' thick) was found on top of this wall by the southeast section.

From these two facts, it is possible to theorize that the well once existed at a height of 130.5' A.S.L. and was covered with wood (and soil to a level of 133.0' A.S.L.). This wood and soil would have collapsed into the well at one point - a theory which can only be proven by further excavation in the well. The discovery of a single wooden beam in the well just above the present limit of excavation of 122.25' A.S.L. adds further proof to this theory.

Thus, by using the information obtained from the excavated structures in conjunction with some speculation based, for the most part, on practicality,

a reconstruction of the passageways, well and casemate was drawn up (Fig. 19). These reconstructed features are set in the framework of a palisade, rather than an earthen bastion, in order to facilitate examination of the structures involved. This drawing is not intended to serve as an exact reconstruction but merely as a sketch of how these structures may have looked. Hence the perspective was slightly exaggerated in the straight passageway.

In conclusion, therefore, reconstruction of the Prince Frederick Bastion would be highly possible, despite certain difficulties. These difficulties may possibly be overcome by additional excavation in the bastion, by continued research in the Archives and possibly even by excavation of the Prince William Bastion. In any event, the discovery of the stone passageways, well, casemate and drains in this bastion has added appreciably to the knowledge of the history and architecture of Fort Beausejour.

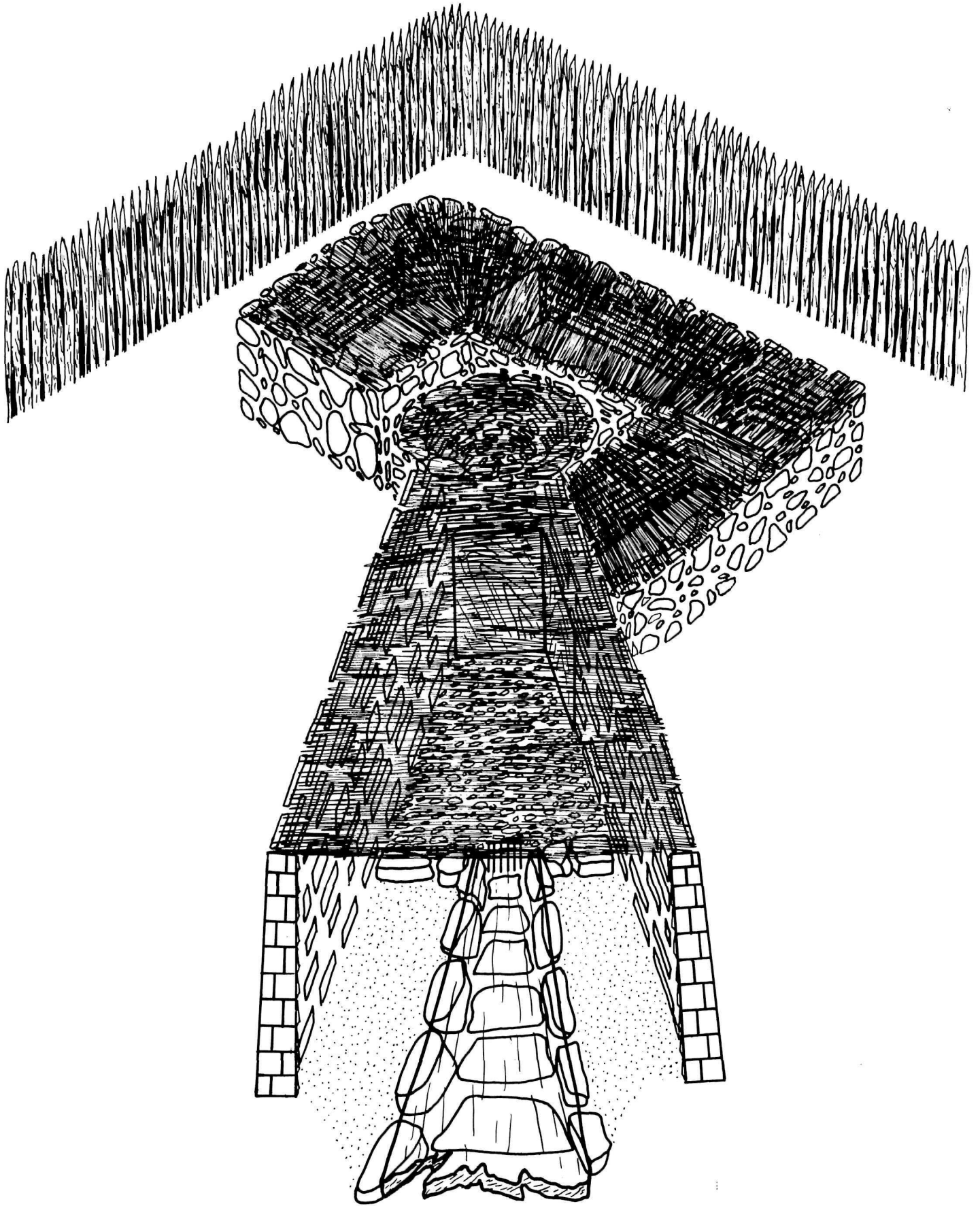

Fig.19 Reconstruction View of Casemate, Well, and Passageways in the Prince Frederick Bastion. Looking East- not to scale

CHAPTER V THE MEN'S BARRACKS - SUB-FLOOR TESTING

Sub-floor testing began during the 1966 excavation season in the Men's Barracks to determine whether or not any other structures were located below the wooden floor of this building - since three buildings were reported to have occupied this site between 1751 and 1852. (Nadon 1966: J:2; L:3). Excavation at that time was limited to a small section of sub-op. 2E16R, which produced what appeared to be the floor boards of another building (66-17-438, 439, 440).

The system of excavation employed in this building this season consisted of three basic steps: (1) removing the debris fallen onto the floor of the building during the previous winter and spring; (2) photographing, recording, and removing the floor boards of the various rooms; and (3) excavating the rooms further.

Unfortunately, a lack of time enabled us to clean and record the floor boards of only three of the rooms, and to excavate, for a few inches, in two of these rooms (No. 1 & 3). A major problem which caused this slowdown was a rise in the water table since 1966, which resulted in the continued flooding of the building throughout the summer.

Structures

In the northern most room of the Men's Barracks (Room 1), several new discoveries were made during the period of excavation. Besides locating the sleeper beams below the floor, more of the brick area in front of the oven and the south face of the oven base were exposed.

In the 1966 excavation, three rows of bricks were found in front of the oven. This year, by removing the soil in front of the oven base, two additional rows were uncovered. The oven base itself consists of five courses of worked stone, with a core of field stone. The latter statement is based on exposure of a very small portion of the core - not on a thorough investigation. One large cut stone covers most of the top of the base, and a fine cut stone is located in the SW corner. The front of the oven base covers an area 2.3' x 5.9' (Fig. 20).

As for the floor itself, it rested on 8 sleeper beams. Six of these are located solely in this room, two extend south through door No. 1 (located in the S.W. corner of Room 1). All the sleeper beams extend from north to south in the room, except for the beam second from west. This beam stops 1.25' south of the north wall. This gap is covered by another short beam (2.0' long) which is placed just west of the other beam (Fig. 21).

A board (0.63' wide and 0.27' thick) is located between the two western most beams in the SW corner of the room. It appears to serve as an extra sleeper beam for the doorway between Room 1 and 2, and extends into Room 1 for 2.0'. The other sleeper beams are all about 0.45' wide and 0.37' thick. Size of these beams varies slightly probably due to pressure of the soil and decay. There does not appear to be a standard distance between these beams, since it varies from 1.75' to 2.95'. The distance between the east and west stone walls and the sleeper beams also varies from 0.4' to 0.7'. Upon further excavation in this room, it was found that blocking was present under several of the beams. An apparently isolated wood plank was also found



Fig. 20 2E16B- Photo of Oven Front
in Room I of the Men's Barracks.
(2E-606-X)

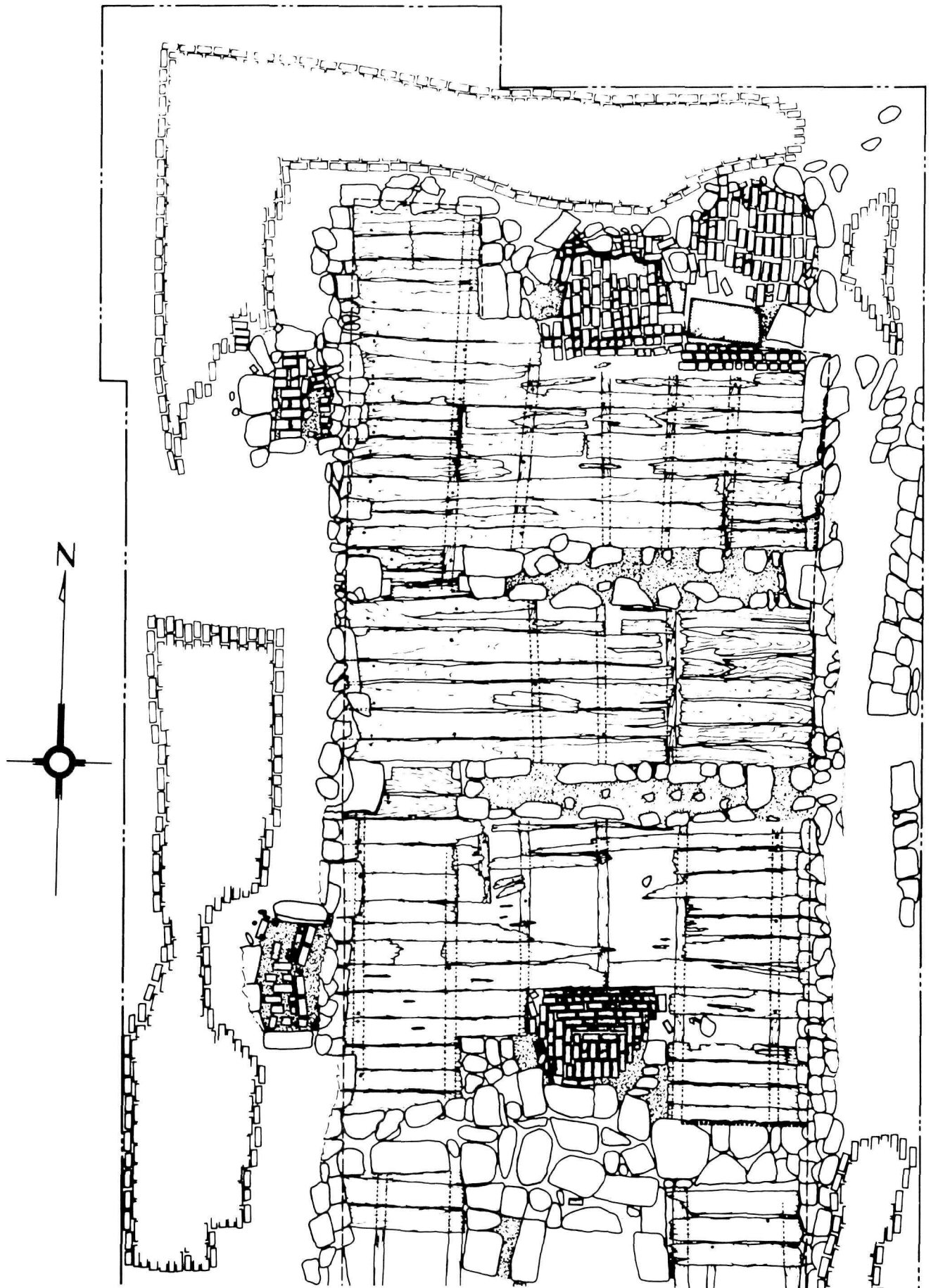

21 2E16: View of sleeper beams and blocking in Rooms 1 and 3 of the Men's Barracks. Scale: 1"-5'. (2E-66-102-14)

in between two of the sleepers. Excavation ceased at the level where a reddish clay layer was found. Hence the blocking was only partially excavated and measurements were not possible.

In Room 2, our work was limited to cleaning off the floor, photographing it and taking elevation readings at various places. Hence no new information was discovered this season in that room.

Room 3, however, proved to be more productive. Here the boards were removed and excavation was carried out for a few inches - until the reddish clay layer found in Room 1 was uncovered. In the area directly in front of the fireplace - an area where the floor boards were practically non-existent - a large amount of pottery and glass fragments were discovered. This was the only real concentration of artifacts found in either Rooms 1 or 3 thus far and is possibly associated with a similar find in this area during the 1966 excavation (66-9-270).

Eleven sleeper beams were found in this room, plus one short beam (1.2' long) at right angles to another in the N.W. corner. Blocking was again uncovered and all but two of the beams are located only in this room. The two longer beams extend into Room 2 below Door No. 2 (located in the N.W. entrance to that room). Although we were not able to measure the thickness of these beams, they would appear to be similar to the ones found in Room 1.

Both of the beams in the eastern section of the floor stop just short of the south wall. Hence, additional short sleeper beams were added - one 2.3' long, the other 1.9'. The beam along the west wall is 0.55' east of the wall, and the one along the east wall is located 1.1' west of it.

Again, the distances between various beams differs, this time from 0.64' to 3.2' - with an average distance of 2.3' to 3.0'.

To conclude, the sub-floor testing in the Men's Barracks had barely commenced before being stopped. Whether or not a sub-floor exists here was not satisfactorily determined, since excavation only went to 0.4' below the floor board level, whereas the sub-floor found in 1966 in Room 4 was located 0.8' below the floor (66-17-438). Hence the significance and interpretation of these structures must be examined at a future date, after excavation has been completed - or at least gone beyond the present depth.

CHAPTER VI THE MEN'S BARRACKS - TEST TRENCHES

Two test trenches were excavated this season in order to determine the nature of the exterior face of the Men's Barrack's west foundation wall. Both trenches were on the west side of the building, and dug in such a way that the stratigraphy of one of the trench walls would fall in line with the stratigraphy of one of the original sup-ops of the building - thus forming one continuous cross-section on both sides of the wall.

The first trench (2E16T) was discontinued shortly after excavation began due to the discovery of numerous bricks, which seemed to form some sort of pattern (Fig. 22). These bricks were found just below the top soil and hence might have been part of a walk of some sort, and since these bricks continued out into the parade ground, it was decided to excavate elsewhere, rather than follow it up, as the season was almost over.

Hence the second trench (2E16U) was designed and excavated along the same lines as 2E16T. This trench was excavated to a depth of 5.7' B.S. (or 120.8' A.S.L.) and it uncovered, besides the anticipated exterior face of the foundation wall, a wooden beam located parallel to and just west of this wall. (1968 excavations proved this to be part of a drainage system for 2E16 which connected with an overall drainage system for the fort proper. Korvemaker's conclusions should therefore be reviewed in this light).

Presuming that the stones excavated in this area form the total width of this wall, then the wall is approximately 2.0' thick, as compared with an average thickness of 2.6' for the walls of the passageway in the Prince

Fig. 22 - 2E16T4: View
of brick feature found
in test trench. Looking
West. 8' scale.
(2E-529-X)



Fig. 23 - 2E16U4 & 5:
View of wood beam in
test trench plus
exterior face of west
wall of Men's Barracks.
6' scale. Looking South.
(2E-560-X)

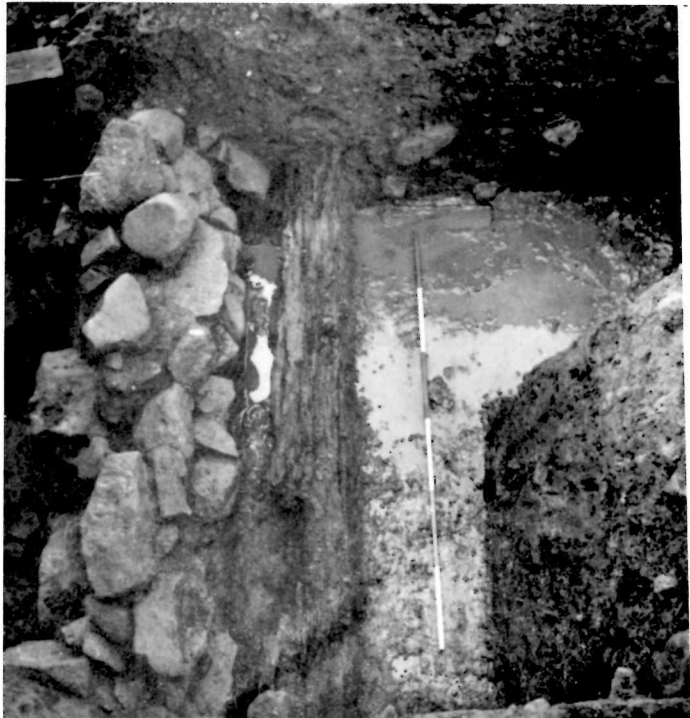

Figure 24

This drawing shows the north wall of the test trench dug west of the Men's Barracks to uncover the west face of the building wall. The stratigraphy is as follows:

- 1) Dark yellowish brown loam (10YR, 3/4).
- 2) Dark reddish brown clay (5YR, 3/4).
- 3) Dark yellowish brown clay (10YR, 3/3).
- 4) Black loam (5YR, 2/2).
- 5) Dark brown clay (7.5YR, 4/4).

126.6'
A.S.L.

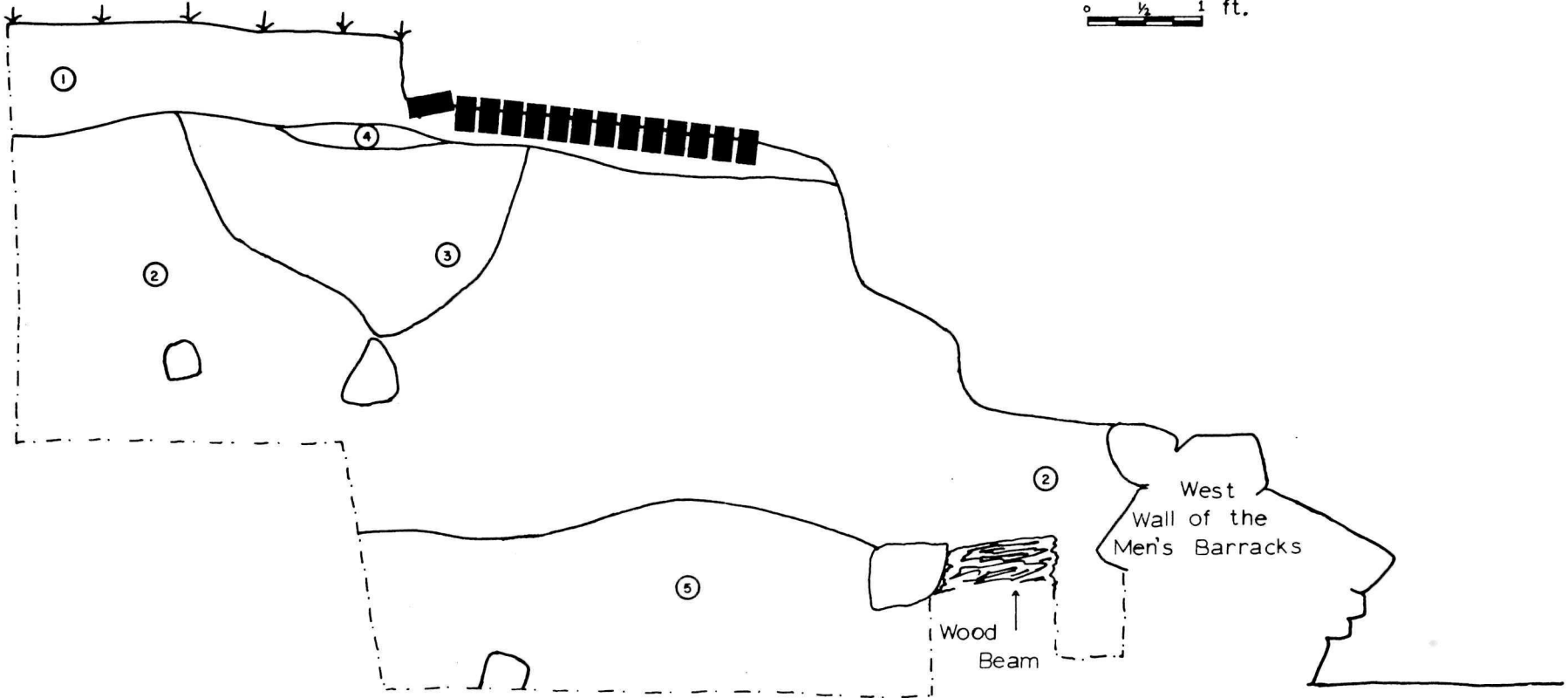

Fig. 24
2E16U - North Face
0 1/2 1 ft.

Frederick Bastion. However, the walls of the Officer's Quarters (2E17-- another building in this fort) are from 1.8' to 2.3' thick, and so it is probable that the 2.0' thick wall of the Men's Barracks is the complete wall.

The interior face is composed of square or rectangular worked stones which have an average size of 1.1' by 0.8' by 1.3'. The exterior face, however, is comprised of field stones placed in rough courses. These stones average 0.6' by 0.7' by 0.5' in size. The core of this wall, like the exterior face, consists of field stones. Although no traces of mortar were found in the exterior face of this wall, the presence of dark greyish brown sand (10YR, 4/2) inside the Men's Barracks, suggests that mortar was used for the interior face.

At 4.5' B.S. (or 122.0' A.S.L.), a wooden beam was uncovered (Fig. 23). This beam is from 0.65' to 0.9' wide and thick, and runs parallel to the stone wall of the Men's Barracks at a distance of 0.6' west of it. Located 0.9' below the top of the existing stone wall, it extends across the entire north-south width of the trench and continues into both the north and south trench faces. This beam is in a very decayed state and has 8 spikes nailed horizontally into the west side. However, there were no traces of any other wood existing in this area; hence, their purpose is not known.

The stratigraphic record of this area might give some sort of clue as to what this beam is a part of. A layer of dark brown clay (7.5YR, 4/4) exists on the west side of the beam and goes almost level with it throughout the trench (Fig. 24). Above this, and east of the beam (between the Barracks' wall and the beam), the soil is dominated by dark reddish brown clay (5YR, 3/4).

From this feature, it is possible to theorize that another structure existed west of the Men's Barracks and that the dark brown soil is fill in this structure. Hence the wood beam may be part of the east wall of such a building or perhaps, a front addition to the Men's Barracks. No such building is described in any of the historical documents however, hence this theory is precisely that - a theory.

In conclusion therefore, this trench, although it has determined the location and thickness of the Men's Barracks' west wall, should be excavated further to determine where the base of the wall is located. This would most likely necessitate enlargement of the present trench, an action which might at the same time reveal exactly what relationship the wooden beam has to this building - if any at all.

REFERENCES

Coleman, K.A.

1966

"Field Notes on Excavations at Fort Beausejour." Report on file, National Historic Parks and Sites Branch, Ottawa.

Nadon, P.

1966

"Historical Report on Fort Beausejour." Report on file, National Historic Parks and Sites Branch, Ottawa.

Rick, J.H.

1962

"Field Notes on Excavations at Fort Beausejour." Report on file, National Historic Parks and Sites Branch, Ottawa.

Trudel, F

1966

"Field Notes on Excavations at Fort Beausejour." Report on file, National Historic Parks and Sites Branch, Ottawa.

TABLE I
 LOT-LAYER CORRELATION FOR THE STRAIGHT
 PASSAGEWAY AND THE WELL

The lot-layer correlations given below are made in reference to the arbitrary cross-section drawings which follow this description. These cross-section drawings are compiled from a combination of lot summaries and stratigraphic drawings, and are located where ideal trench walls would have been. The layer numbers used below hold true for all of the drawings presented:

- 1) The top soil of this bastion consists mainly of a layer of dark brown loam (7.5YR, 3/2) - layer 1. It was included in all of the following lots: 2E20F1, F11, G1, G8, G19, G26, G28, H3, H4, H12, N1, N9, P1; as well as along the tops of lots 2E20F2, F12, G2, G9, G10, G20, G27, G29, H20, N2, N10, P2, 2E16C1. A portion of lot 2E20G21 also was comprised of this soil type.
- 2) Below this layer, a layer of dark brown sandy loam (7.5YR, 3/2) plus field stones - layer 2 - was found directly below lot 2E20F11, just north of the passageway wall. This layer was found in lot 2E20F12.
- 3) A layer of dark reddish brown sandy loam (5YR, 3/4), plus field stones layer 3 - covers much of the bastion directly below the top soil. This layer was found to comprise most of lots 2E20F3, F12, G10, G20, G27, G29, H13, H20, H5, N2, N4, N6, P2. It was also included in some portions of lots 2E20F2, F4, G30, H2, 2E16C1.

- 4) Layer 4 consists of dark brown loam (7.5YR, 3/2) plus field stones and was found north of the straight passageway directly below layer 3. It existed mainly at the bottom of lots 2E20F12, G27, and H20, with a small portion extending into 2E20G32.
- 5) Directly along the exterior north wall of the straight passageway a layer of dark reddish brown loamy clay (5YR, 3/2) - layer 5 - was found. It might be a footer trench - although its shape differs somewhat from this type of trench. It was found in lots 2E20F12, G24, G27, and H20.
- 6) Layers 6 and 7 form a deposit of mortar detritus plus brick fragments. The soil in the top portion of this layer consists of dark brown sandy loam (7.5YR, 4/2) - layer 6 - and it is included in lots 2E20F4, F5, G2, G3, G5, H14, N11. The bottom soil is of the dark reddish brown sandy loam variety (5YR, 3/4) - layer 7 - and is found in lots 2E20F5, F7, F10, G5, G14, G15, G22, G30, G31, H5, H9, H21, K1, K2, K3, K4, K5, N5, P3. This layer extends across most of 2E20F, the entrance to 2E20M, and the southern portion of 2E 20G - laying directly below layer 3 in most cases.
- 7) Below the mortar layer, several layers of dark brown loam exist. One, a layer of dark reddish brown loam (5YR, 3/4) - layer 8 - is found in lot 2E20F6. Another, a layer of very dark brown loam (10YR, 2/2) - layer 9 - is found in lots 2E20F9 and H18. It includes charcoal pieces and is located directly below layers 7 and 8. Layer 10, which consists of dark reddish brown loam clay (5YR, 3/4) is found in lots 2E20F8, G16, H7, H15, H22.

- 8) Layer 11 consists of a mixture of dark reddish brown sandy clay (5YR, 3/4) and dark brown sandy loam (7.5YR, 4/2) and was found in lot 2E20L4, which lies directly below the bottom lots of 2E20F, G and H (inside the passageway).
- 9) Layers 12 and 13 consist of a mixture of reddish brown clay (5YR, 4/4), dark reddish grey clay (5YR, 4/2) and dark yellowish brown clay (10YR, 3/4). Lots 2E20L2, L5, L7, and P4 form these two layers.
- 10) In 2E20G32 - a north extension to this sub-op. - much of the soil directly below the top soil consists of strong brown loam (7.5YR, 5/6) - layer 14. This soil does not occur elsewhere in this area of the bastion. The base of this lot consists of a layer of brown loamy sand (7.5YR, 5/2) - layer 15 - and it too is found only in this lot.
- 11) Layer 16 consists of dark brown loam (7.5YR, 3/2) plus charcoal and is found in lots 2E20G2, G16, H6, L1, N11, and part of 2E20L5.
- 12) A layer of dark reddish brown loam (5YR, 3/4) plus charcoal - layer 17 - is found directly below the mortar detritus layer in 2E20G. It is found in lot 2E20G23 and also in 2E20N3 as a lens in the middle of a layer of dark reddish brown sandy loam - layer 3.
- 13) Layer 18 is located directly below layer 17 in 2E20G and consists of dark brown loam (7.5YR, 3/4). It is found in lots 2E20G25, G31 and part of 2E20G3.

- 14) Lots 2E20G4 and G6 comprise a layer of dark brown sandy loam (7.5YR, 3/2) and are located below the West section of the mortar detritus layer (layer 19).
- 15) Layer 20 - dark brown sandy clay (7.5YR, 4/2) - was found south of the passageway and comprised most of lot 2E20G7.
- 16) Layer 21 was located just on top of and on both sides of the drain in the straight passageway. It consists of a mixture of reddish brown sandy clay (5YR, 4/6) and yellowish red sandy clay (5YR, 4/8). Included in this layer were lots 2E20L6 and the bottom of lots 2E20L2 and P4.
- 17) The drain itself was excavated in two lots - 2E20P5 and P7, both of which consisted of dark reddish grey sandy clay (5YR, 4/2) - layer 22.
- 18) Layer 23 consists of dark reddish brown sandy loam (5YR, 3/4) and it was located directly below the top soil in the area of the entrance to the L-shaped passageway. The deposit was quite small and was found in the top of lots 2E20H5 and H20.
- 19) A layer of dark reddish brown sandy clay (5YR, 3/4) and dark brown sandy loam (7.5YR, 5/2) - layer 24 - covered much of the top of the straight passageway lying on top of sub-op 2E20L. It was found in lots 2E20G4, G14, G17, G18, H8, H23.
- 20) 2E20N7 and N8, located west of the L-shaped passageway, consisted largely of a layer of reddish brown loam (5YR, 4/4). This layer - # 25 - is located directly below lot 2E20N6.

- 21) In the northeast corner of 2E20F, two layers of loam were found, which formed part of a deep loam layer above the well (2E20K). The topmost layer consisted of dark brown loam (7.5YR, 4/4) and dark brown sandy clay (7.5YR, 3/2) - layer 26. The layer directly below it consisted of dark reddish brown loam (5YR, 3/4) - layer 27. Both layers were found in lots 2E20F1, F2, H1, H2 - within 0.5' of the surface.
- 22) Layer 28 is located directly above the mortar detritus layer in 2E20G and consists of dark reddish brown sandy clay (5YR, 3/4). It includes some charcoal and brick pieces and is found in lots 2E20G12, G13 and a small section of 2E20G2.
- 23) Between this last layer and the top soil, a layer of dark brown sandy loam (7.5YR, 3/2) plus charcoal and faint mortar traces is present - layer 29. It is found in lots 2E20G9, G11, and part of 2E20G2.
- 24) Layer 30 consists of dark brown clay (7.5YR, 3/2) plus mortar detritus and is found in lots 2E20K6, K7, K8 - inside the well. Directly below it lies a layer of reddish brown sandy clay (5YR, 3/2) and dark brown sandy clay (7.5YR, 3/2) plus mortar debris - layer 31. This layer consists of lots 2E20K9 and K10 and appears to continue beyond the present depth of excavation.

Section Through AB

Looking East

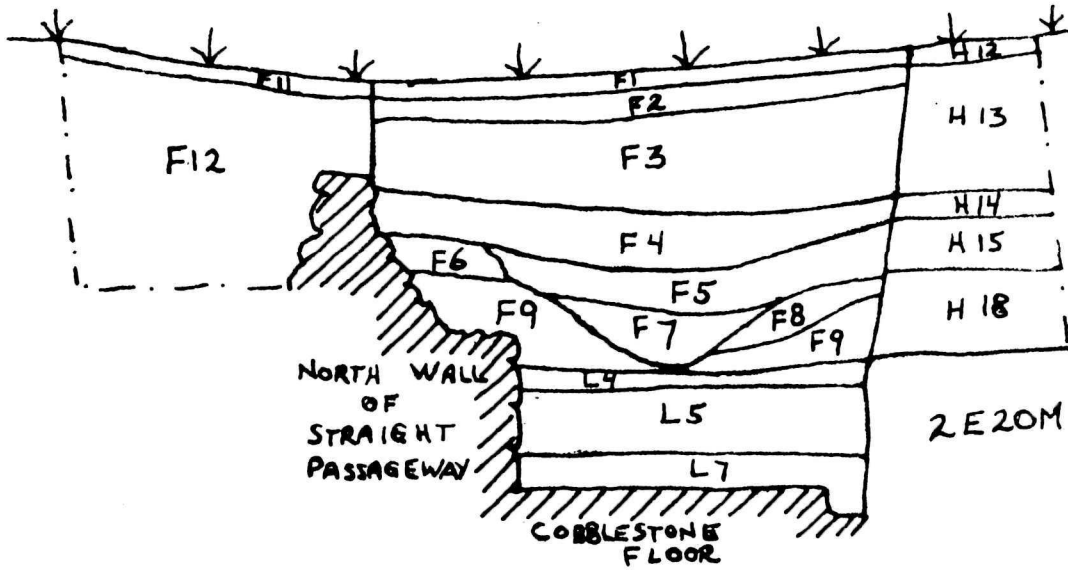

APPROXIMATE SCALE

1" = 5'

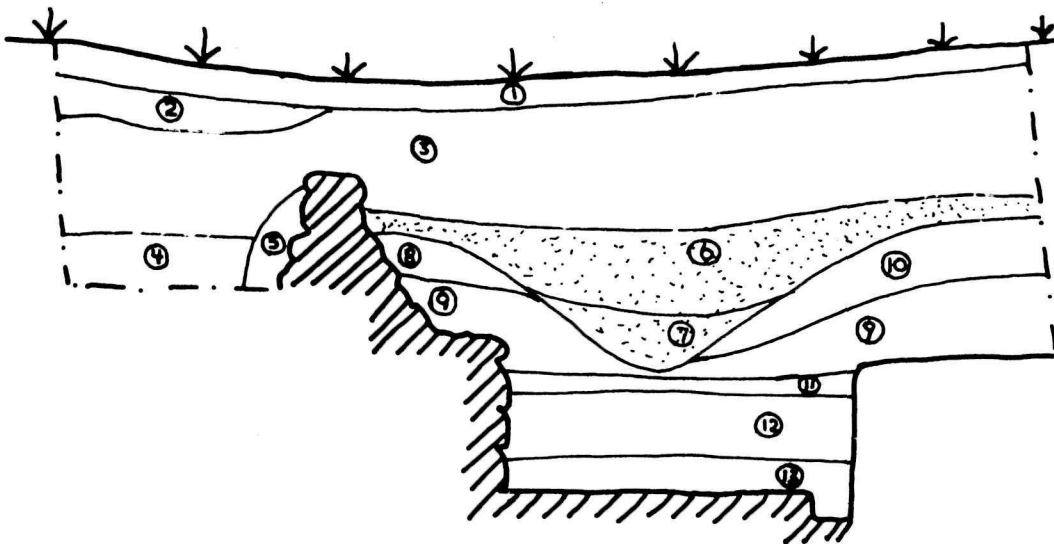

Section Through CD

Looking East

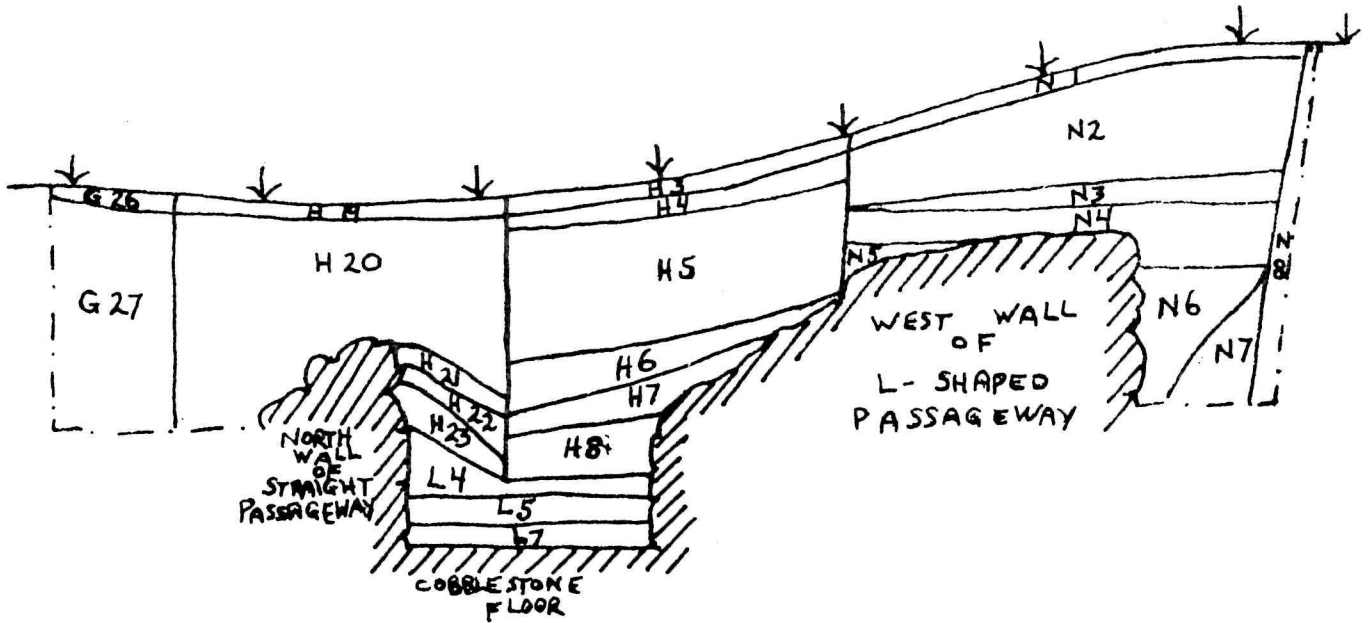

APPROXIMATE SCALE

1" = 5'

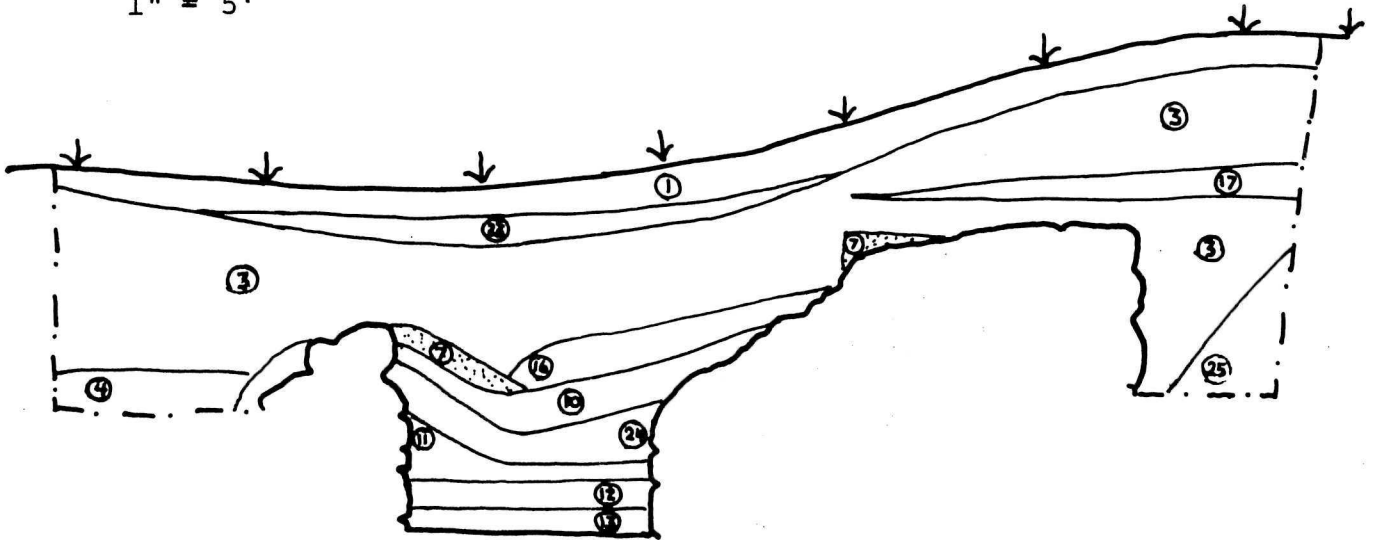

Section Through EF Looking East

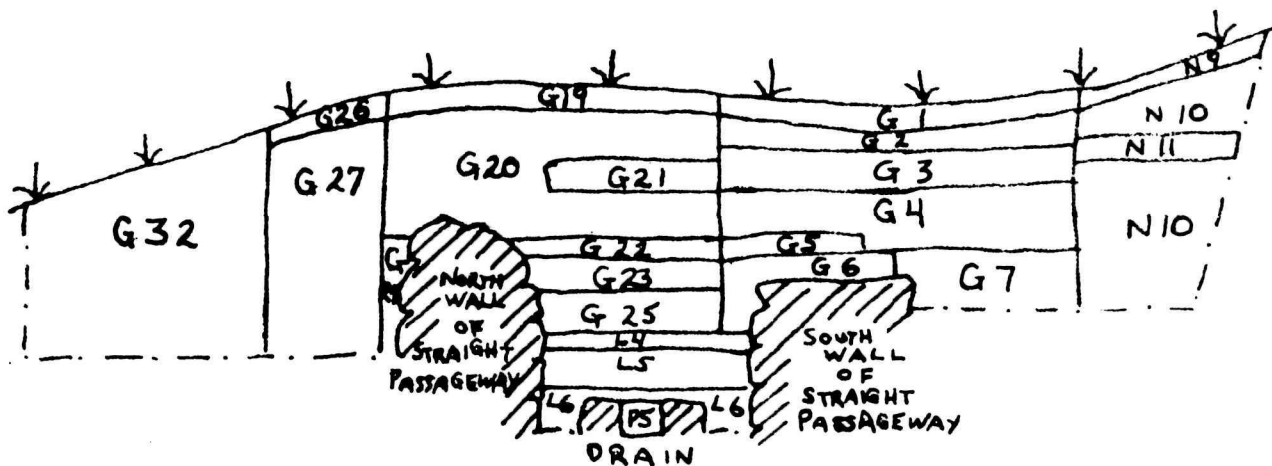

APPROXIMATE SCALE

$$1" = 5'$$

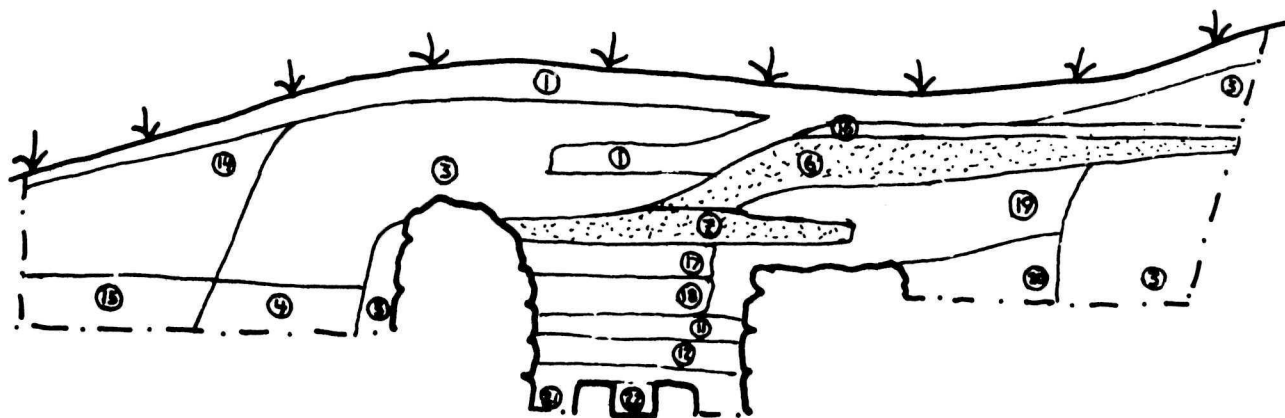

Section Through GH

Looking South

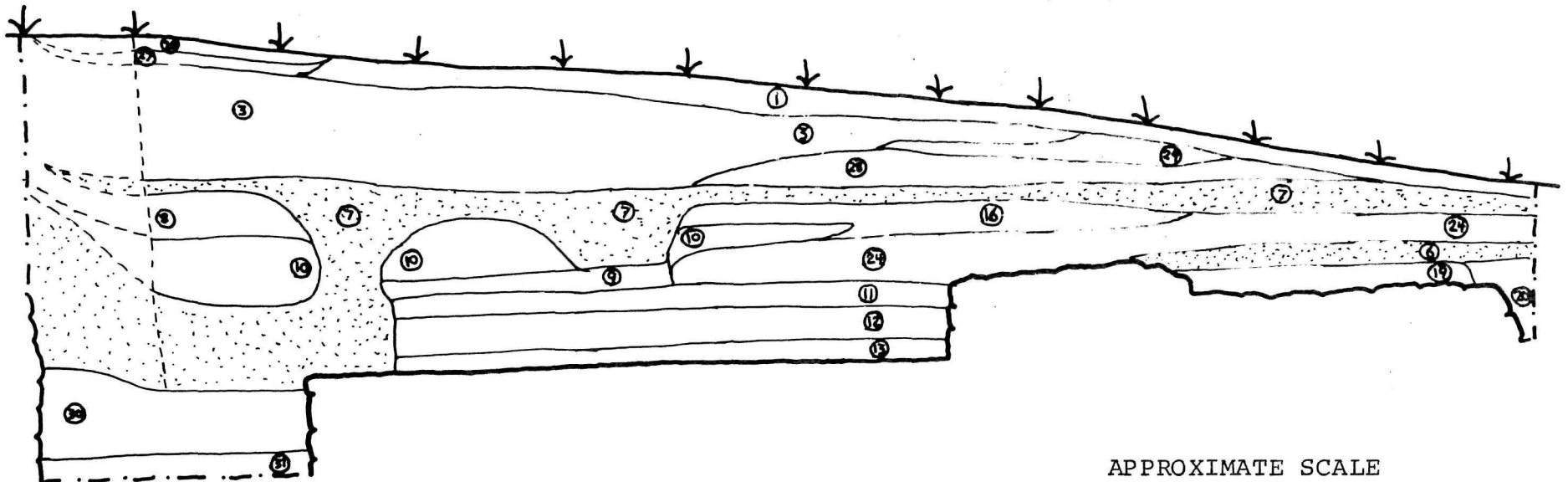
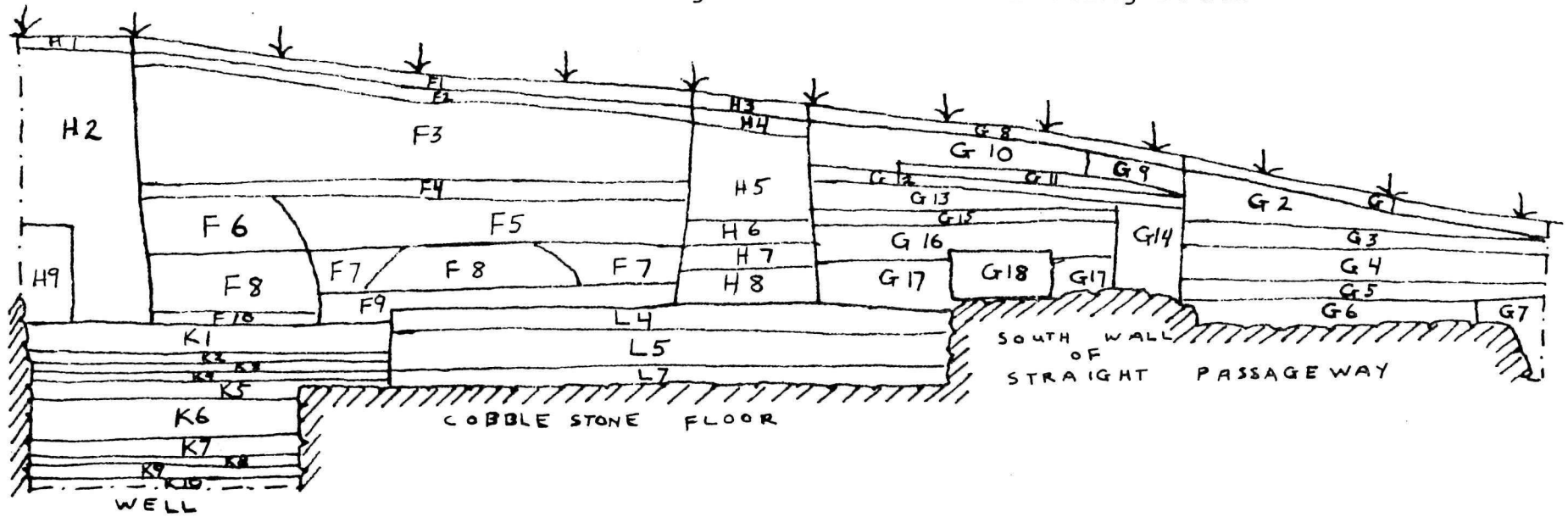

APPROXIMATE SCALE
1" = 5'

Section Through JK Looking South

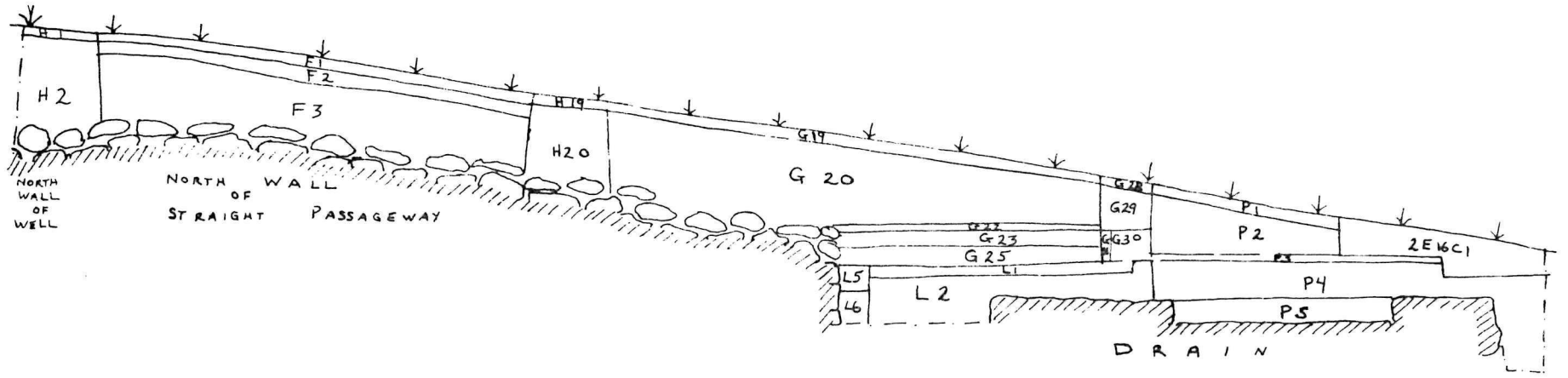

77

